

People's Democratic Republic of Algeria
Ministry of Higher Education and Scientific Research
Mouloud Mammeri University of Tizi Ouzou



Faculty of Building Engineering
Civil Engineering Department

Lecture Handout:

ROAD INFRASTRUCTURE DESIGN



Intended for 2nd year Master's Degree Students in Civil Engineering: Civil and Industrial Construction

Presented by Dr. SI SALEM Abdelmadjid

Academic year: 2024-2025

TABLE OF CONTENTS

Preface	i
----------------------	----------

Chapter I: Overall overview of roadways

I.1. Introduction	1
I.2. Historic of road manufacturing	1
I.3. Road definition	5
I.4. Materials in road construction.....	6
I.4.1. Coarse aggregates	6
I.4.2. Fine aggregates.....	7
I.4.3. Hydrocarbon-based binders	7
I.4.4. Synthetic materials	8
I.4.5. Recycled materials	9
I.5. Type of pavement structures.....	10
I.5.1. Flexible pavements.....	10
I.5.2. Rigid pavements	10
I.5.3. Pavements with hydraulic binder treated base.....	11
I.5.4. Hybrid pavements.....	12
I.5.5. Cement based-concrete pavements	12
I.5.6. Composite pavements	13
I.6. Vehicle loads on pavements.....	14
I.6.1. Vertical loads.....	14
I.6.2. Tangential forces	15
I.6.3. Dynamic forces.....	16
I.6.4. Influence of load duration on pavement behavior	17
I.7. Traffic analysis	17
I.8. Road classification	20
I.9. Roads terminology.....	22
I.9.1. Cross-section profile	23
I.9.2. Longitudinal profile.....	24
I.9.3. Plan Profile payout.....	24
I.6. Conclusion.....	25

Chapter II: Vehicle kinematics

II.1. Introduction.....	27
II.2. Mechanical aspect notice.....	28
II.2.1. Trajectory.....	28
II.2.2. Rectilinear motion.....	28
II.2.3. Circular motion.....	29
II.3. Isolated vehicle.....	31
II.3.1. Engine effort.....	31
II.3.2. Braking traction.....	32
II.3.3. The stopping distance.....	34
II.3.4 Vehicle Stability.....	34
II.4 Grouped vehicles.....	36
II.4.1. Safety distance.....	36
II.4.2. Overtaking distance.....	38
II.5. Conclusion.....	39

Chapter III Road pavement design

III.1. Introduction.....	40
III.2. Parameters for pavement design.....	40
II.2.1. Traffic.....	41
II.2.2. Climate and environment.....	41
II.2.3. The supporting Soil.....	42
II.2.4. Structure type and materials.....	42
II.2.5. Construction and maintenance.....	43
II.3. Methods for designing pavement sub-layers.....	44
II.7.1. Empirical methods.....	44
II.7.2. Analytical and theoretical methods.....	52
II.7.3. Numerical methods.....	53
II.4. Conclusion.....	56

Chapter IV: Geometric features of traffic lane roads

IV.1. Introduction.....	57
IV.2. Plan alignment profile.....	57
IV.2.1. Rules in plan profile designing	62
IV.2.2. Elements of plan profile.....	63
IV.3. Longitudinal profile.....	67
IV.3.1. Rules for drawing the longitudinal profile	68
IV.3.2. Geometric elements of the longitudinal profile.....	69
IV.3.3. Transitions in the longitudinal profile.....	69
IV.4. Cross-section profile	70
IV.4.1. Elements of the cross-section profile	71
IV.4.2. Classification of the cross-section profile	73
IV.5. Conclusion.....	75

Chapter V: Earthworks in road construction

V.1. Introduction	76
V.2. Definition and terminology.....	76
V.3. Earthworks objectives	78
V.3.1. Execution of Embankments.....	80
V.3.2. Construction of the roadway support platform.....	82
V.4. Treatment of in-situ soils.....	84
V.4.1. Types of soil treatment.....	86
V.4.2. Works process	87
V.5. Road earthworks volume calculation	91
V.5.1. Cross-sectional method (or cross-sectional area method)	91
V.5.2. Grid method (or contour method).....	92
V.5.3. Trapezoidal method.....	92
V.5.4. Volume of prisms method	93
V.6. Numerical tools in road earthwork volume calculation	94
V.6.1. Geographic information systems	94
IV.6.2. 3D modeling and cad software	96
IV.7. Conclusion.....	96
References.....	97-101

PREFACE

The present lecture handout is intended for students enrolled in the second year of the Master's degree in civil engineering, more specifically in civil and industrial construction specialization. The course deals with the design and dimensioning of road projects, and more specifically pavements and roadways. After the achievement of the course, students will be introduced to roads infrastructures design and management. Indeed, it is to point out that learners need the recommended foundational knowledge and concepts especially in soil mechanics, construction materials, and physics.

Road pavements can be defined as the part of a transportation route dedicated to vehicle traffic. Roadways are composed of multilayer structures implemented on a foundation known as the pavement support platform. A pavement is essentially designed to resist the mechanical actions of vehicles and transfer these loads to the underlying foundation soil without causing permanent deformations in either the soil or the pavement. Through these chapters, the lecture aims to achieve few objectives to provide knowledge and tools for the following issues:

- An overview of road systems to understand why we built roadways and their crucial role in the development of civilizations. To better understand its technical aspects in a historical context, one must embrace project management principles and grasp the social and economic issues surrounding this field.
- Master skills on vehicle kinematics and pavement method design to better understand how vehicles move through space, taking into account the various parameters that influence their movement. In addition, to involve comprehension in selecting the necessary materials with the required properties and determining the thicknesses of the various layers in the pavement structure.
- Geometric features of traffic lane roads which were defined in a spatial design by the plan alignment, the longitudinal profile and the cross profile. The geometric characteristics of these elements must correspond to the most cost-effective solution and ensure certain minimum conditions defined by the natural environment, particularly the topography, geology and the anticipated future traffic.
- Earthworks in road construction to shape the foundation and the platform that will support the pavement and associated equipment. This shaping involves operations to alter the topography of a site to provide the road with the geometric characteristics specified according to the execution and design plans.

The objectives outlined in this educational document helps to understand the key factors in the design and management of a communication route project. In the context of allowing students to gain a deep understanding of the concepts in the roadways transportation planning, an exhaustive set of references with very high scientific and educational quality is presented at the end of the document.

Chapter I: Overall Overview of Roadways

I.1. Introduction

Roadways are a crucial part of transportation systems, primarily designed to accommodate vehicle traffic. They are complex, multilayered structures built upon a supportive foundation, known as the road support platform. The primary function of a pavement roadway is to bear the mechanical loads and stresses imposed by vehicles, transferring these forces to the underlying foundation without causing excessive permanent deformation in the bituminous surface and the soil beneath.

This chapter aims to address several key questions: First, it explores why roads are built, emphasizing their historical significance in the development of civilizations and their role in shaping technical and social progress. Understanding this context is essential to grasp the broader social and economic impacts of road infrastructure. Second, it examines how to study road projects, highlighting the need for a comprehensive approach that integrates various disciplines, such as environmental, geological, hydraulic, traffic, urban planning, and economic studies. These preliminary analyses are critical before embarking on any fieldwork. Finally, the chapter considers how to process road projects, which requires a solid understanding of geotechnical principles, excavation techniques, and quality control measures to ensure successful implementation.

I.2. Historic of road manufacturing

The history of road construction techniques spans millennia, evolving from simple pathways to the intricate and durable infrastructure we rely on today (*Gong, et al 2022*). In ancient civilizations like Mesopotamia, roads were primarily rudimentary dirt paths used for transporting goods and armies. These early roads were often little more than cleared paths, with some regions utilizing stones or reed mats for basic surfacing. In ancient Egypt, roads were constructed to transport materials like limestone for the pyramids and support trade routes, with stone slabs or compacted sand forming the surface. As civilizations advanced, roads began to take more structured forms, particularly in the Roman Empire, which

revolutionized road-building with advanced techniques and engineering. Roman roads were built with multiple layers, including large stones for a foundation, followed by gravel and smaller stones for stability, and topped with flat paving stones for a smooth surface. This layered approach, combined with the cambered design to allow for drainage, ensured Roman roads were long-lasting and able to withstand both heavy use and harsh weather.

Following the fall of the Roman Empire, road construction in Europe experienced a decline. Roads became little more than dirt tracks, especially in rural areas, with maintenance and engineering expertise fading (Peng Guo, et al 2022). During the medieval period, roads were often rough and poorly maintained, as there was less emphasis on infrastructure development. Cobblestone surfaces began to appear in urban centers, but rural roads were often merely cleared paths through forests or farmland. It wasn't until the early modern era, particularly in the 16th and 17th centuries, that road construction techniques began to improve again, driven by the needs of trade and transportation. In fact, efforts were made to formalize road networks. Materials such as gravel, cobblestones, and bricks became more common, particularly for urban roads, while rural roads were still largely neglected (G. Doré, H. Zubeck 2008).

In the 18th century, the introduction of turnpike roads marked a significant shift in road construction (Giani, et al 2015). These roads, maintained by tolls, were designed for better quality and durability. The most notable development during this period involved using crushed stone or gravel, compacted tightly to create a smooth, solid surface that allowed for better drainage and reduced erosion. This method revolutionized road building, as it did not require large stones for the foundation, instead relying on tightly compacted small stones to form a durable surface (Krylatov, et al 2020).

Figures I.1 and I.2 illustrate some examples of roman causeways and the procedure of the pavement manufacturing.



Figure I.1. Example of an ancient roman causeway. *Source:* https://fr.wikipedia.org/wiki/Voie_romaine

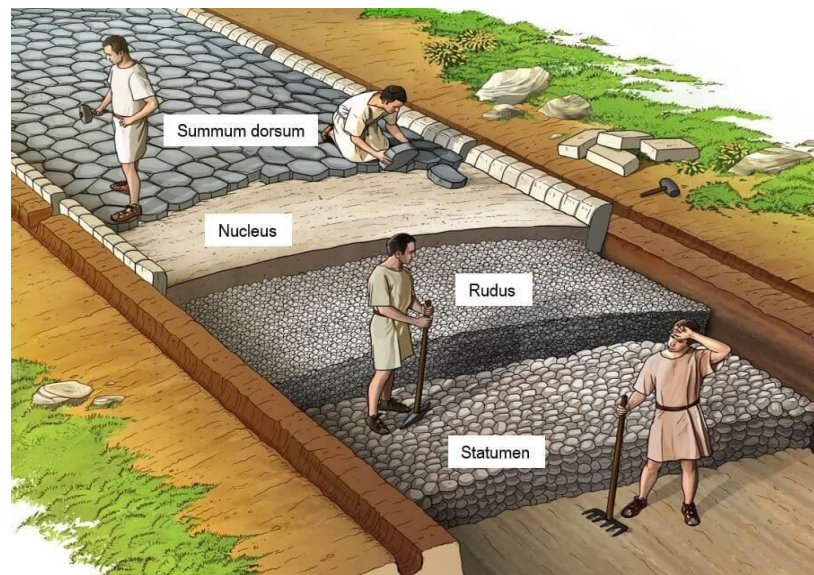

Figure I.2. Roman causeway. Source: <https://www.geotech.hr/en/ancient-roman-roads-a-monument-to-history-and-road-construction/>

The 19th century saw significant advancements with the advent of asphalt paving and the introduction of concrete. In the mid-1800s, asphalt was first used in Europe and the United States as a material for road surfaces (AASHTO, 1993). It offered a smoother and more durable alternative to previous materials. Hot-mix asphalt, where the material was heated and then poured onto the surface, became the standard method for paving roads. At the same time, concrete emerged as another important material, with the first concrete road being constructed in 1893 (Ioannou, et al 2024). Concrete roads were particularly valued for their strength and long-lasting nature. The 19th century also saw the development of early road-paving machinery, which helped increase efficiency and speed in construction.

The 20th century marked the rise of the automobile, which fundamentally changed road construction. As the number of vehicles on the road grew, so did the need for better infrastructure. Roads were built with higher durability to withstand the wear and tear of motor traffic. Concrete and asphalt continued to dominate road materials, but construction methods became increasingly mechanized. The development of the U.S. Interstate Highway System in the 1950s was a major milestone in road construction, introducing vast networks of roads designed for high-speed traffic (AASHTO, 2009). These highways required advanced engineering techniques, including soil stabilization and reinforced concrete for bridges and overpasses, and they set the standard for modern road construction.

In the 21st century, road construction has continued to evolve with a focus on sustainability, technological innovation, and smart infrastructure. New materials such as recycled asphalt and rubberized asphalt have become more common, reducing environmental impact while still offering durability (Russo, et al 2024; Shehhi, et al 2023; Al Kheder, et al 2022). The concept of "smart roads," which integrate sensors and solar panels, is also emerging, aiming

to improve traffic management, energy efficiency, and even vehicle charging. Modern techniques in road construction now incorporate geosynthetics like geotextiles and geogrids to enhance soil stabilization, drainage, and support, and innovations like cold in-place recycling allow for the reuse of existing road materials, making construction both more cost-effective and environmentally friendly (Kornilova, et al 2024). These materials not only reduce the environmental impact of road construction but also provide durability and cost-effectiveness. With the help of 3D modeling and GPS technology, road construction has become more precise and efficient, reflecting the ongoing advancements in both engineering and technology.

A Comparison between ancient and modern techniques of roads construction is illustrated in Figure I.3 and 1.4.

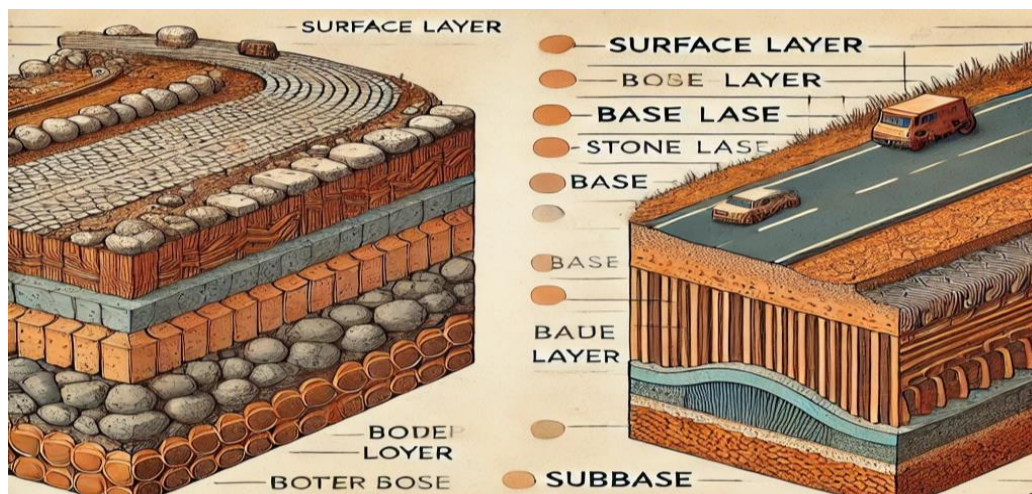

Figure I.3. Comparison between ancient and modern techniques of road construction.

Source: <https://fr.slideshare.net/slideshow/pathologies-de-chausses/26220084>



Figure I.4. Examples of modern and ancient roadways. Source:

<https://theromancultureinfo.weebly.com/roman-architecture-and-engineering-in-the-modern-world.html>

I.3. Road definition

A roadway is a multi-layered structure comprising three main components, each fulfilling a distinct role as shown in Figure I.5. At its foundation lies the subgrade, which consists of a compacted and stabilized soil prepared to serve as the base for the entire roadway structure. The subgrade layer plays a vital role in supporting the loads transmitted by the upper layers, ensuring stability and durability of the roadway over time. Typically, the subgrade is topped by a subbase layer, and together they form the support platform of the roadway.

The subbase layer serves dual purposes. During construction, it protects the subgrade, ensures surface leveling, and facilitates the movement of construction machinery. Once the roadway is in service, it plays a critical role in homogenizing the mechanical properties of the underlying soil or fill and enhances the long-term load-bearing capacity of the structure.

Above the subbase, the base layer and foundation layer constitute the structural layers of the roadway. These layers provide the mechanical strength required to withstand vertical traffic loads and distribute the resulting pressures evenly across the support platform, ensuring that deformations remain within acceptable limits.

The surface layer, which includes the wearing course and, optionally, an intermediate binder course, serves two primary functions. Firstly, it protects the structural layers from water infiltration, and secondly, it improves user comfort by providing a smoother driving surface, particularly when the surface quality is high.

Beyond these core layers, roadways also incorporate essential features such as shoulders, ditches, and the subgrade (see Figure I.6) to ensure stability, safety, and ease of maintenance. A roadway is specifically engineered to endure mechanical forces exerted by vehicles and transfer them to the underlying foundation soil without causing permanent deformations in either the roadway structure or the foundation soil.

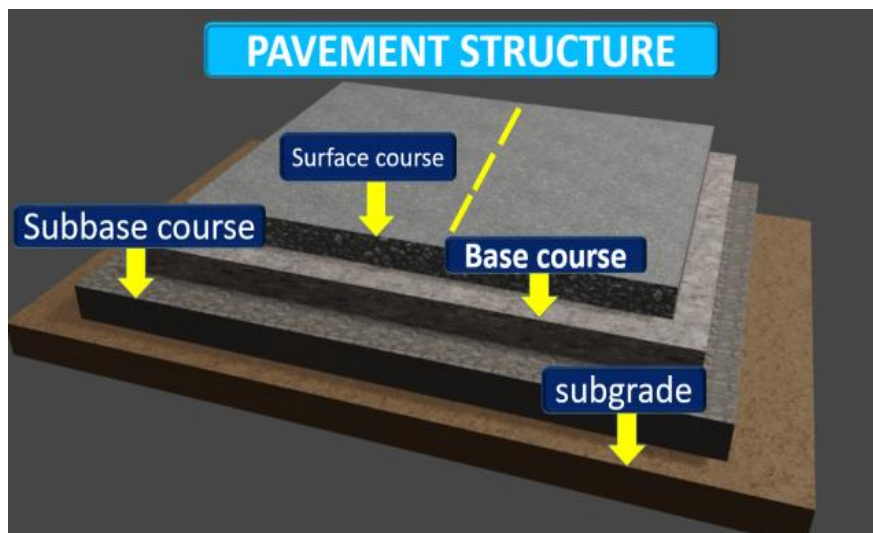

Figure I.5. Terms used in the pavement structure of a roadway. *Source:* <https://civilsynergy.wordpress.com/2020/08/11/pavement-and-its-types/>

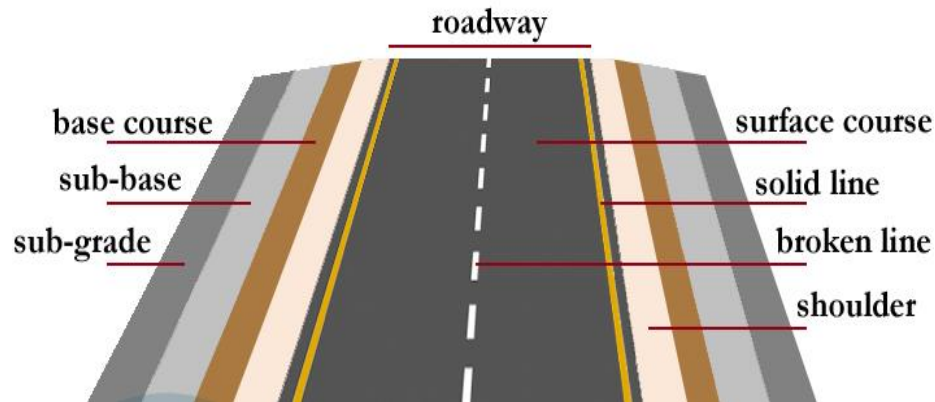

Figure I.6. Definition of road components. *Source :*

<https://engineeringdiscoveries.com/flexible-pavement-layers-in-road-construction/>

I.4. Materials in road construction

Road construction relies on a variety of materials, each selected for its specific properties to ensure strength, durability, and functionality. The materials used are typically divided into natural materials, such as soil, aggregates, and stone, and processed materials, including asphalt, concrete, and stabilizers. These materials are combined strategically to form the different layers of a roadway, such as the subgrade, subbase, base, and surface layers. The choice of materials depends on several factors like traffic load, environmental conditions, and cost-effectiveness, with the primary goal of constructing a safe, long-lasting, and efficient transportation network.

I.4.1. Coarse aggregates

The stony, gravelly, or sandy materials used in road construction (i.e. Figure I.7) are divided into two main categories. The open tight gradation ones present a high proportion of voids. These are typically obtained by crushing hard stones from quarries and are used as surface dressing gravel. In addition, dense materials with spread gradation are used. Intended to be compacted, they provide resistance through compaction and cohesion.



Figure I.7. Gravelly and stony materials used in road construction and protection. *Source:*

<https://saintpierredentremont.org/savoie/campagne-de-gravillonnage/>

I.4.2. Fine aggregates

In road construction, fine aggregates are small granular materials, such as sand or crushed stone dust, that pass through a 4.75 mm sieve. They are used to fill voids, improve the workability of mixtures, and enhance the strength and stability of layers like asphalt or concrete pavements. These materials, which are increasingly used are shown in Figure I.8.



Figure I.8. Fine aggregates used in road construction. *Source:* <https://www.granova.de/en/application-areas/road-construction/>

I.4.3. Hydrocarbon-based binders

Hydrocarbon-based binders like bitumen and tar shown in Figure I.9 are widely used in the construction of flexible pavements due to their physical properties, which make them especially suitable for this purpose. These products are very viscous at ordinary temperatures, but either through heating or special preparation, they can be used in a fluid form. One can cite the following raw materials:

Bitumen: a black, sticky, and viscous substance derived primarily from petroleum refining. It is widely used as a binder in road construction materials, particularly in the creation of asphalt concrete. When mixed with aggregates such as gravel, sand, or crushed stone, bitumen forms a durable and weather-resistant material ideal for paving roads, highways, and airports. Its ability to resist water, oxidation, and degradation makes it a long-lasting solution for road surfaces.

Tar: a thick, dark liquid obtained from the distillation of coal, wood, or petroleum. Although it was once widely used in road construction, especially for surfacing and binding aggregates, it has largely been replaced by bitumen due to environmental concerns and its tendency to degrade more quickly under exposure to weather and traffic. While it shares some similarities with bitumen in its binding properties, tar is more prone to oxidation, leading to faster deterioration of the pavement surface.

Asphalt: refers to a mixture of bitumen (or sometimes tar) and aggregates like crushed stone, sand, or gravel. This mixture, known as asphalt concrete, is the most common material used in modern road construction. Asphalt is favored for its flexibility, durability, and ability to withstand heavy traffic loads, while also offering excellent waterproofing properties. It is the final paved surface that provides smooth, long-lasting, and efficient roads.



Figure I.9. Hydrocarbon-based Binders. Sources: <https://www.express.fr/> and <https://technimafrance.com/fr/blog/enrobe-a-froid-proprietes-avantages-utilisation-fabrication-n50>

I.4.4. Synthetic materials

Synthetic materials are increasingly being used in road construction to improve the performance, durability, and sustainability of pavements. These materials are engineered or manufactured to provide specific properties that enhance the traditional materials used in road construction.

One common synthetic material is geotextiles, which are permeable fabrics made from synthetic fibers like polypropylene or polyester. Geotextiles are used for soil stabilization, filtration, drainage, and separation in road construction. They help reinforce the subgrade, prevent mixing of different layers, and improve the overall load-bearing capacity of the road.

Polymers are another important category of synthetic materials. They are often added to bitumen to create polymer-modified bitumen, which improves flexibility, elasticity, and resistance to rutting and cracking. This makes roads more durable under varying temperatures and heavy traffic loads.

Recycled plastics have also found applications in road construction. By blending shredded plastics with bitumen or using plastic waste as a partial replacement for aggregates, the road's environmental footprint is reduced while enhancing its strength and longevity. Plastic roads are gaining attention for their potential to recycle waste and improve the pavement's resistance to water and wear.

Additionally, synthetic fibers like glass, aramid, or polypropylene fibers are incorporated into asphalt or concrete to improve tensile strength, reduce cracking, and enhance durability. These fibers distribute stress more evenly and increase the lifespan of road surfaces.

Overall, synthetic materials are revolutionizing road construction by offering innovative solutions that address challenges such as durability, environmental impact, and performance under extreme conditions. For more clarity, Figure I.10 illustrates an example of polyester fibers-based geotextiles in road construction usage.



Figure I.10. Polyester fibers-based geotextiles in road construction usage. *Source:* <https://oceangeosynthetics.com/importance-of-geotextile-in-road-construction/>

I.4.5. Recycled materials

Recycled materials are increasingly used in road construction to enhance sustainability, reduce costs, and minimize environmental impact. Common materials include reclaimed asphalt pavement, recycled concrete aggregate, and industrial byproducts like fly ash and slag. These materials improve durability, reduce the need for virgin aggregates, and lower greenhouse gas emissions. Innovations such as plastic waste and rubber from old tires are also being integrated into asphalt and base layers, enhancing flexibility and longevity. Figure I.11. shows an example of incorporating plastic waste into a road asphalt mixture.



Figure I.11. Incorporating plastic waste into a road asphalt mixture. *Source:* ADB <https://events.development.asia/>

I.5. Type of pavement structures

The pavement structures refer to the layered system of materials used to build a road or pavement, designed to distribute traffic loads, provide a durable surface, and resist environmental wear. The structure is typically composed of several layers, each serving a specific function to ensure the pavement performs well under traffic loads and environmental conditions. The types of pavement structures can be broadly classified based on their composition and load distribution characteristics.

I.5.1. Flexible pavements

Flexible pavements are road surfaces made of multiple layers that can flex under traffic loads, distributing stress efficiently to the subgrade. They typically consist of a bituminous (asphalt) surface layer, base course, sub-base, and compacted subgrade. The flexibility of these pavements helps them adapt to temperature variations and minor subgrade settlements, reducing the risk of cracks. These structures feature a relatively thin bituminous surface layer (less than 15 cm) as shown in Figure I.12, which may be reduced to a coating for very low-traffic pavements, and rests on one or more layers of untreated granular materials. The overall thickness of the pavement is generally between 30 and 60 cm.

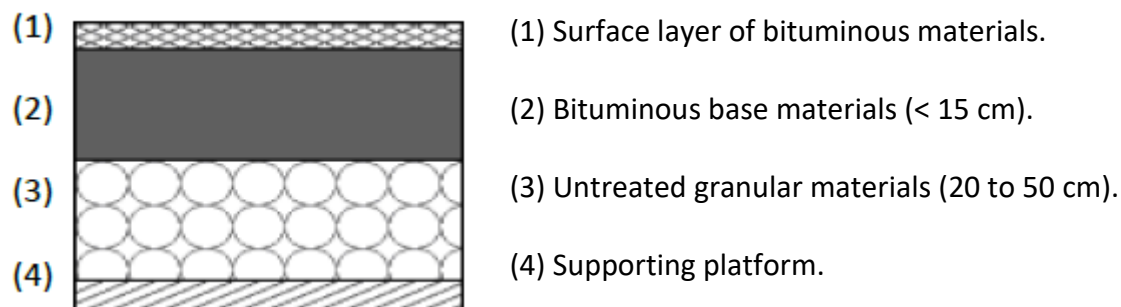

Figure I.12. Constitutive materials of a flexible pavement. *Source:* Meziani F. (2023)

I.5.2. Rigid pavements

Rigid bituminous pavements offer improved durability, reduced maintenance needs, and better resistance to temperature variations compared to conventional flexible pavements. They are commonly used in heavy traffic areas like highways and airports, where both strength and flexibility are essential.

These structures shown in Figure I.13 consist of a bituminous wearing course on a pavement body of materials treated with hydrocarbon binders, typically consisting of one/two layers (base and foundation). Typically feature a high-modulus asphalt layer over a stabilized or semi-rigid base, the thickness of the base layers is most often between 15 and 40 cm. The main differences between flexible and rigid pavement are presented in Figure I.14.

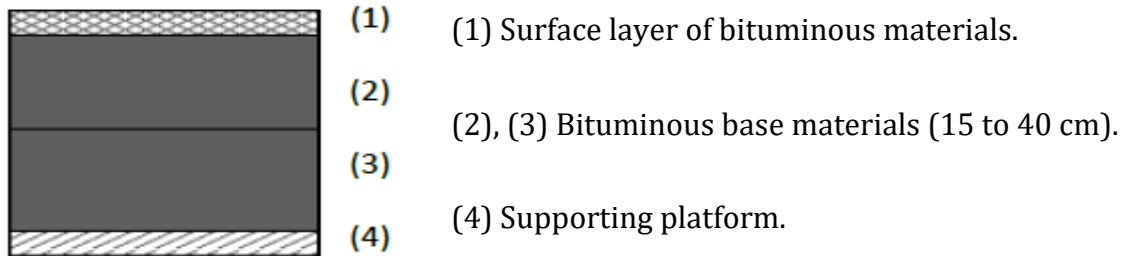

Figure I.13. Constitutive materials of a rigid pavement. *Source:* Meziani F. (2023)

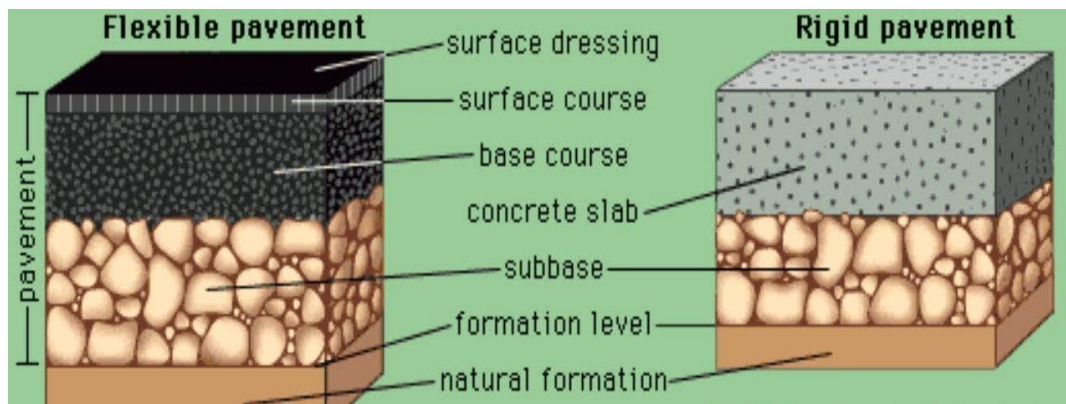

Figure I.14. Comparison between flexible and rigid pavement. *Source:* <https://www.britannica.com/technology/flexible-pavement>

I.5.3. Pavements with hydraulic binder treated base

These structures are pavements where the base layer is stabilized and strengthened by mixing aggregates with a hydraulic binder, such as cement, lime, or fly ash. The binder undergoes a chemical reaction with water, hardening the base layer and improving its load-bearing capacity, durability, and resistance to moisture. This treatment enhances the performance of the pavement, particularly in areas with weak subgrades or high traffic loads.

Commonly referred to as semi-rigid pavements, they consist of a bituminous surface layer on a base of materials treated with hydraulic binders, arranged in one or two layers (base and foundation), with a total thickness of approximately 20 to 50 cm, as shown in Figure I.15.

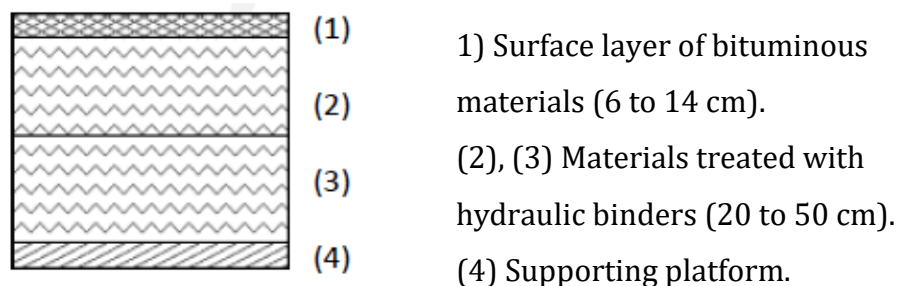

Figure I.15. Constitutive materials of a pavements with hydraulic binder treated base. *Source:* Meziani F. (2023)

I.5.4. Hybrid pavements

Hybrid pavement system that combines the strength of rigid pavements with the flexibility of bituminous materials. These pavements typically feature a high-modulus asphalt layer over a stabilized or semi-rigid base. These structures consist of a wearing course and a base layer made of bituminous materials (base thickness: 10 to 20 cm) over a foundation layer of materials treated with hydraulic binders (20 to 40 cm), as shown in Figure I.16. Mixed structure pavements are characterized by the ratio of the thickness of the bituminous materials to the total thickness of the pavement being approximately one half.

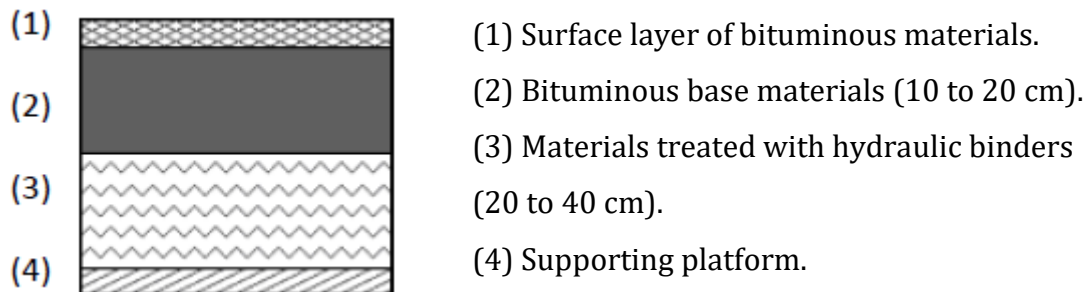

Figure I.16. Constitutive materials of a mixed structure pavement. *Source:* Meziani F. (2023)

I.5.5. Cement based-concrete pavements

Rigid pavements constructed primarily using a mixture of cement, water, fine aggregates (sand), coarse aggregates (gravel or crushed stone), and sometimes additives to enhance specific properties. The cement acts as a binding agent that hardens and forms a solid, durable slab capable of supporting heavy traffic loads. These structures feature a layer of cement based-concrete, 15 to 40 cm thick, that serves as the wearing course, possibly covered by a thin layer of bituminous materials. The concrete layer rests either on a foundation layer (made of materials treated with hydraulic binders or cement based-concrete), a drainage layer of untreated granular material, or a layer of bituminous mix resting on a sub-base treated with hydraulic binders. Figures I.17-19 provide some examples of cement based-concrete pavements.

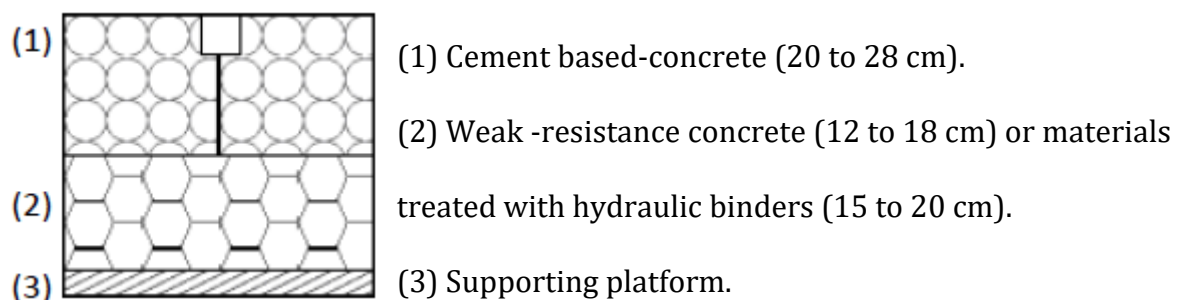

Figure I.17. Pavement with non-tied slabs and foundation. *Source:* Meziani F. (2023)

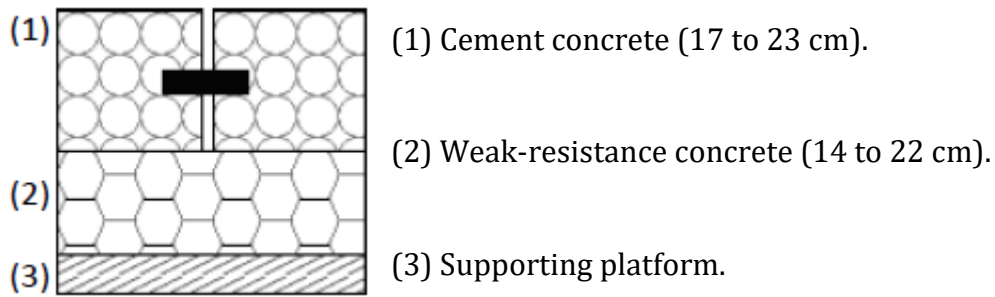

Figure I.18. Pavement with tied slabs and foundation. *Source:* Meziani F. (2023)

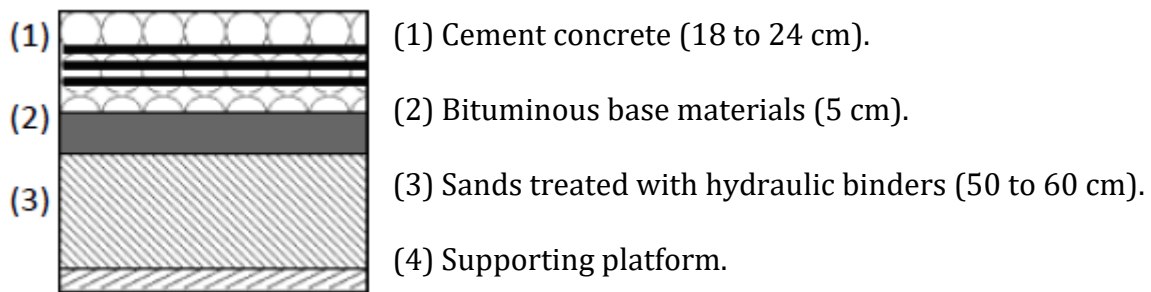

Figure I.19. Continuous reinforced concrete pavement. *Source:* Meziani F. (2023)

I.5.7. Composite pavements

The multi-layered composite pavement structures that incorporate both flexible and rigid materials, typically consisting of a rigid concrete base overlaid with a flexible asphalt surface. This combination utilizes the high strength and durability of the concrete base to support heavy loads while the asphalt layer provides a smooth, resilient, and easily maintainable driving surface, enhancing performance and extending the pavement's lifespan.

These structures combine a layer of cement based-concrete with layers of bituminous materials. Some examples are provided in Figure I.20 and 21.

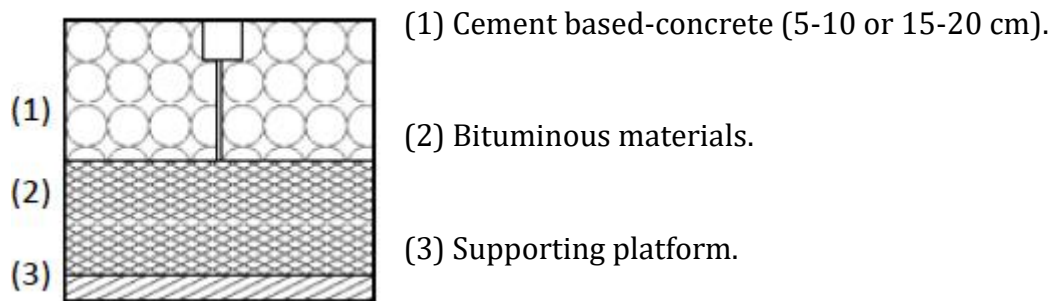

Figure I.120. A thin bonded cement based-concrete pavement. *Source:* Meziani F. (2023)

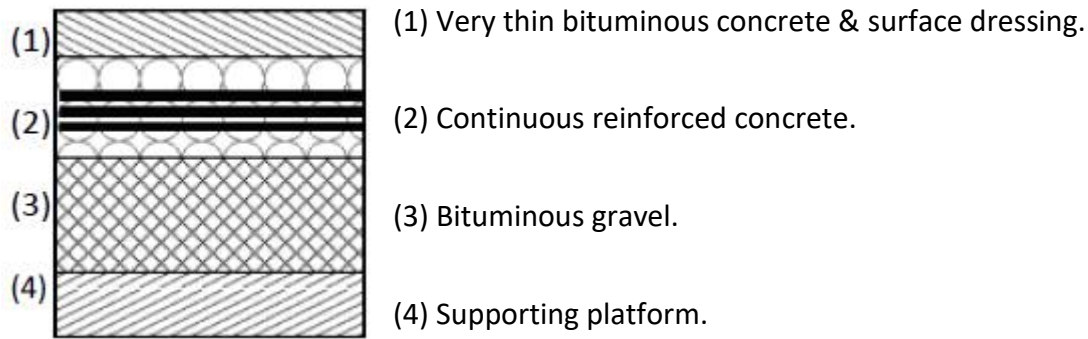

Figure I.21. Structure of a continuous reinforced concrete pavement on bituminous aggregate. *Source:* Meziani F. (2023)

I.6. Vehicle loads on pavements

The performance and durability of a pavement depend significantly on its ability to withstand vehicle loads. These loads are the forces exerted by vehicles, including their weight, axle configuration, and wheel distribution, which directly impact the pavement structure. Proper understanding and consideration of vehicle loads are crucial in pavement design to ensure long-term functionality and prevent premature failures such as rutting, cracking, or deformation.

Vehicle loads influence not only the structural integrity of the pavement but also the material selection and thickness of its layers. Heavy traffic, such as trucks and buses, exerts higher stresses on pavements compared to lighter vehicles, necessitating robust designs. Thus, an accurate assessment of vehicle loads is fundamental to achieving a balance between performance, safety, and cost-efficiency in road construction. The pavement surface must ensure safe and comfortable traffic at all times.

I.6.1. Vertical loads

Vertical loads on pavements primarily come from the weight of vehicles and environmental factors. These loads can be classified into: static, dynamic or respective loads. In addition, temperature changes, moisture, and freeze-thaw cycles contribute to vertical stress by causing expansion, contraction, and weakening of pavement layers. The weight of vehicles is transmitted in the form of pressures (i.e. Figure 22). Road regulations limit loads to 150 kg per cm of rim (wheel), but the pressure can locally reach considerable values (AASTHO, 2012).

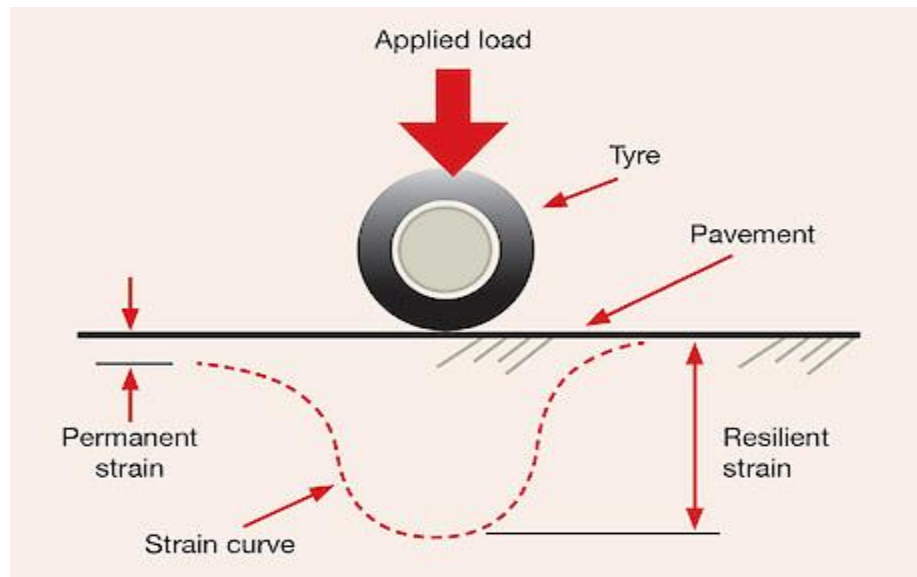

Figure I.22. The weight of vehicles transmitted in the form of vertical pressures. *Source:* <https://docs.nzfoa.org.nz/live/nz-forest-road-engineering-manual/6-pavement-design-subgrade-preparation-pavement-construction/6.1-traffic-loading/>

I.6.2. Tangential forces

Tangential forces are lateral and longitudinal stresses exerted on pavement surfaces due to vehicle movements such as braking, acceleration, and turning. These forces arise from the interaction between vehicle tires and the pavement surface and are particularly significant in areas of high traffic intensity, sharp curves, or steep gradients.

The impact of tangential forces on pavements can lead to surface wear, loss of skid resistance, and deformation, especially if the pavement design and materials are inadequate. Understanding tangential forces is essential for ensuring the pavement's durability and safety, as well as for optimizing surface texture and material selection to withstand such stresses over time. Proper design strategies mitigate these forces, preserving pavement integrity and ensuring reliable performance under dynamic traffic conditions. The wheels exert tangential forces on the pavement through:

- Transmitting engine or braking effort;
- Rotating non-driven wheels;
- Resisting transverse forces.

Additional forces arise from the elasticity of the tires, notably due to:

- The flattening of the tire, where the rolling radius (the fictitious radius of a circular wheel rolling at the same angular speed) is both less than the tire radius and greater than the height of the axle above the pavement.
- Transverse forces acting on the vehicle (wind, camber, bumps, etc.) cause tire drift.

All these phenomena involve friction that wears down both tires and pavements, as shown in Figure I.23.

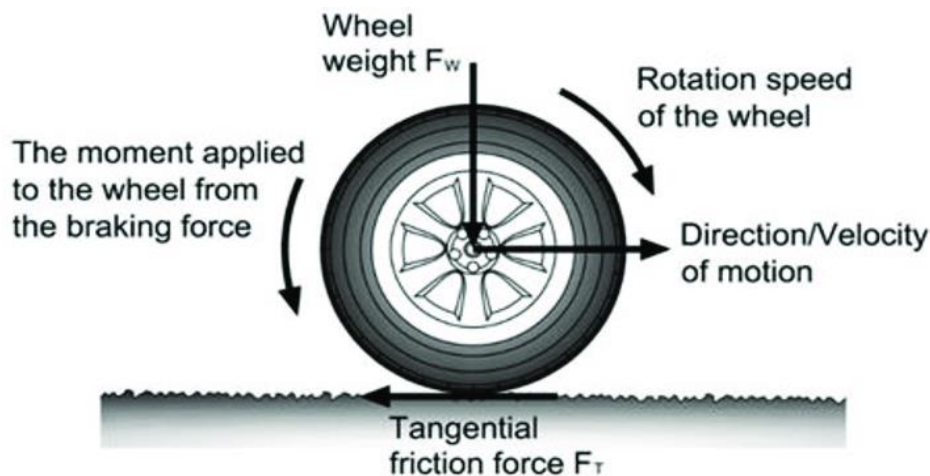

Figure I.23. Shema of tangential friction loads. *Source:*

<https://www.sciencedirect.com/science/article/pii/S1877705815013624?via%3Dihub>

I.6.3. Dynamic Forces

Dynamic forces are the additional loads exerted on pavements due to the motion of vehicles, including effects from acceleration, deceleration, uneven road surfaces, and vehicle suspension systems. Unlike static loads, dynamic forces fluctuate and are influenced by factors such as vehicle speed, weight, and the roughness of the pavement surface.

These forces can significantly impact pavement performance by causing fatigue, cracking, and surface deformation over time. Roads subjected to high-speed or heavy traffic often experience amplified dynamic forces, requiring robust design and material solutions. Understanding and accounting for dynamic forces during pavement design ensures better resistance to wear and tear, enhancing the pavement's lifespan and reducing maintenance needs.

An automobile with a chassis axle (Figure I.24) supported by suspension components that hold the rigid frame carrying the engine, body, etc. Suspension components are springs that deform under static forces and, especially, dynamic actions related to overcoming obstacles.

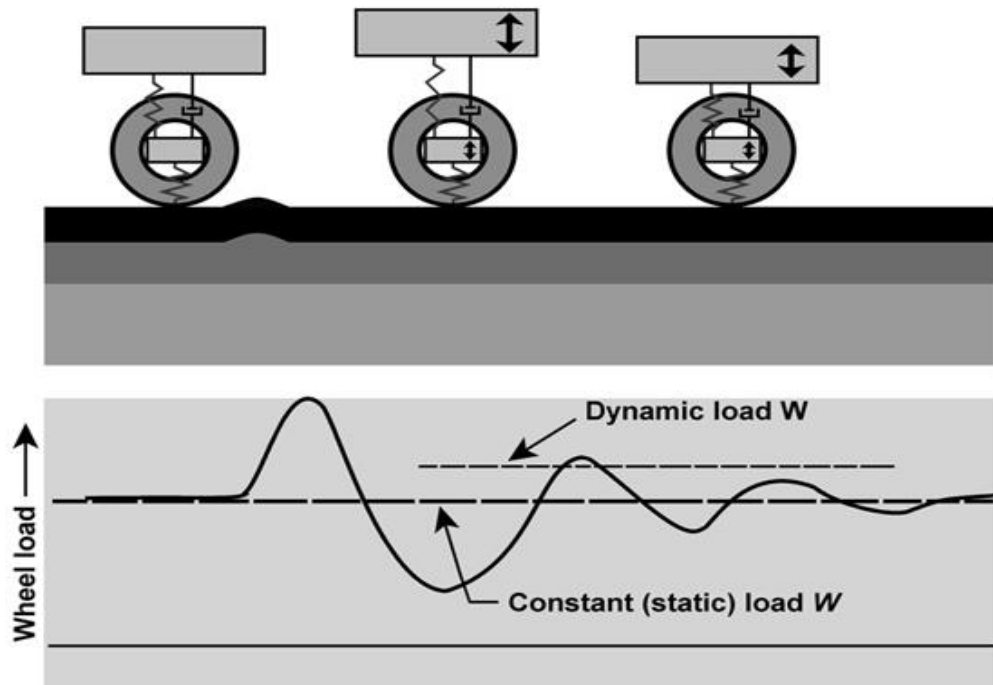

Figure I.24. Shema of dynamic loads on a pavement. *Source:* Doré and Zubeck (2008).

[https://doi.org/10.1061/41072\(359\)33](https://doi.org/10.1061/41072(359)33)

The vibrations have a natural period specific to the road section (type, thickness). Their amplitude depends on the nature of the wheels and the pavement surface (type of surfacing). A Shema of caused vibration by dynamic loads on a pavement is given in Figure I.25

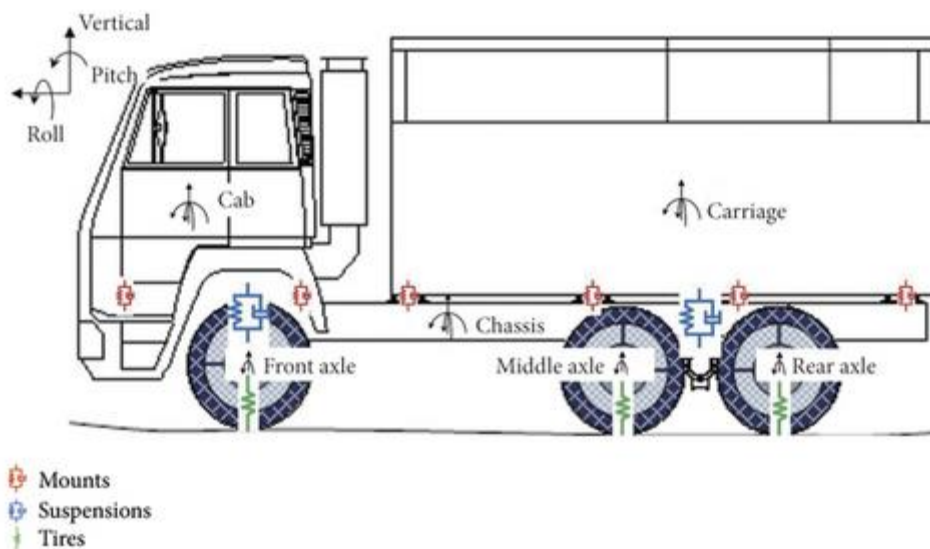

Figure I.25. Shema of caused vibration by dynamic loads on a pavement. *Source:*

<https://onlinelibrary.wiley.com/doi/10.1155/2021/6695639>

I.6.4. Influence of load duration on pavement behavior

The behavior of pavements under vehicle loads is significantly influenced by the duration of the applied load, which varies depending on whether the vehicle is moving rapidly, moving slowly, or stationary. The response of pavement materials, elastic recovery or plastic deformation depends largely on the time the load remains applied.

In fine-grained soils, short-duration loads do not allow sufficient time for liquid movement within the soil matrix, limiting deformation. Conversely, long-duration loads can cause consolidation as water slowly flows through the soil pores, leading to settlement. Similarly, hydrocarbon binders such as tar and bitumen, which exhibit viscoelastic properties, resist deformation under brief loads but may experience more noticeable creep and flow under sustained loads.

Given that pavements are made up of a combination of materials, including soils, binders, and concrete, the duration of load application plays a critical role in their performance. Addressing this sensitivity is essential during pavement design to ensure resistance to deformation under varying traffic conditions and to extend the pavement's lifespan.

I.7. Traffic analysis

Traffic analysis on roads is the systematic study of vehicle and pedestrian movement to understand patterns such as traffic volume, speed, and flow. This process evaluates key factors like the number and type of vehicles using the roadway, their speeds, and their interactions, including lane usage and merging behavior. Additionally, it identifies peak and off-peak traffic variations to assess how demand changes throughout the day, week, or year.

Traffic analysis is essential for road design and management, enabling engineers to determine appropriate lane capacities, pavement thickness, and geometric features. It also informs traffic control measures, such as signals and signage, and helps identify high-risk areas that may require safety interventions like speed limits or pedestrian crossings. Moreover, it supports urban planning by guiding infrastructure expansion, public transport development, and zoning decisions. By ensuring roads meet current and future demands, traffic analysis minimizes congestion, reduces accidents, and promotes efficient and sustainable transportation networks.

Traffic corresponds to the number of vehicle passages over a specified period. The weight of the vehicles is transmitted to the pavement in the form of pressures through the tires. For a passenger car, this pressure is around 0.1 MPa (or 1 kg/cm²). However, it is around 0.7 MPa under a truck wheel (*ASSHTO, 2009*)

Figure I.26 illustrates a comparison of the influence surface of loads applied by light-duty truck and heavy one.

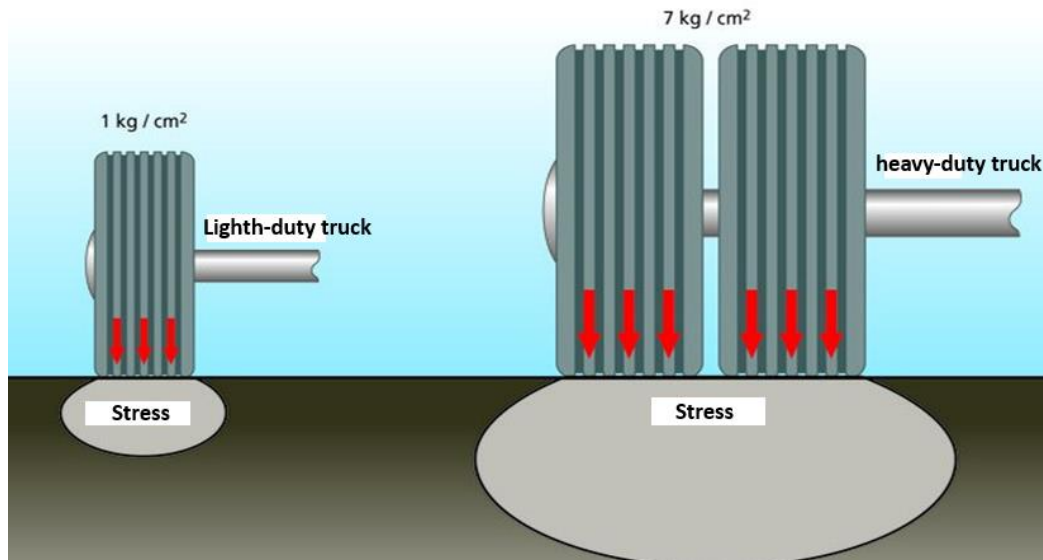

Figure I.26. Influence of the load transmitted by a vehicle and a truck wheel on a pavement.

Source: <https://www.infociments.fr/route/caracteristiques-generales-des-chaussees>

In the field of traffic studies, it is essential to define commonly used terms:

- **Traffic volume:** The number of vehicles passing a specific point on a road within a given time period, commonly measured in vehicles per hour or per day.
- **Traffic density:** The number of vehicles occupying a given length of roadway at a particular instant, usually expressed in vehicles per kilometer or mile.
- **Traffic flow:** The movement of vehicles along a roadway, typically measured in vehicles per hour and influenced by factors like speed, density, and road capacity.
- **Level of service:** A qualitative measure describing traffic conditions on a road, ranging from free flow to severe congestion.
- **Saturation flow rate:** The maximum flow of vehicles per lane per hour under ideal conditions, used for traffic signal design and capacity analysis.
- **Design hourly volume:** The estimated traffic volume during the peak hour of a typical day, used for designing road capacity.
- **Traffic congestion:** A condition where traffic demand exceeds road capacity, causing slow speeds, delays, and increased travel times.
- **Road capacity:** The maximum number of vehicles that a road section can accommodate under given conditions, expressed in vehicles per hour.
- **Traffic impact assessment:** A study evaluating the potential effects of new developments or infrastructure changes on existing road networks.

Some terms are introduced road construction and traffic engineering to better understand traffic patterns and design roads to accommodate varying traffic volumes based on time and season:

- **Weekend daily traffic:** refers to the average volume of traffic that passes a specific point on the road during weekends. Traffic volumes often increase on weekends due to leisure travel, tourism, shopping, or recreational activities. Understanding this traffic flow helps in designing roads, bridges, and highways that can handle weekend congestion, ensuring safety, capacity, and smooth travel.
- **Average daily summer traffic:** refers to the average volume of traffic observed on a road during the summer months, typically a specific range of months when traffic is heavier due to vacation travel, tourism, or seasonal activities. Indeed, roads often experience a significant increase in traffic during the summer, particularly in tourist destinations or areas with recreational attractions. This metric helps in understanding the seasonal traffic peak and guides the design and planning of infrastructure to manage high volumes, reduce congestion, and improve safety during these periods.

The located materials under the wheels experience very different stresses depending on whether a car or a truck passes over. Only trucks are considered when determining traffic classes. Traffic classes are defined by the average daily traffic of heavy vehicles (HV) with a payload greater than 5 tons traveling on the pavement. The classification provided by (AASHTO, 2022) is given in Table I.1.

Table I.1: Classification of traffic classes according to (AASHTO, 2012)

Road class	Average daily traffic (HV/day)
Class T6	From 0 to 10 HV/day
Class T5	From 10 to 25 HV/day
Class T4	From 25 to 50 HV/day
Class T3-	From 50 to 100 HV/day
Class T3+	From 100 to 150 HV/day
Class T3	From 50 to 150 HV/day
Class T2	From 150 to 300 HV/day
Class T1	From 300 to 750 HV/day
Class T0	From 750 to 2000 HV/day

I.8. Road classification

The classification is a system used to categorize roads based on factors such as traffic volume, functional use, design specifications, and traffic type. This classification helps guide road planning, design, and maintenance, ensuring that roads are built and maintained to accommodate the appropriate level of traffic and functionality. Table I.2 provide a general overview of common types of road classifications:

Table I.2: Road classification according to (AASHTO, 2012)

Classification Type	Category	Description
By Function	Arterial Roads	High-capacity roads that connect major regions and facilitate long-distance travel.
	Collector Roads	Medium-capacity roads that link arterial roads to local roads.
	Local Roads	Low-capacity roads that provide direct access to residences, businesses, or farms.
By Access Control	Controlled Access Roads	Roads with restricted entry/exit points, such as highways or expressways.
	Uncontrolled Roads	Roads with unrestricted access, commonly seen in rural or urban areas.
By Surface Type	Paved Roads	Roads surfaced with asphalt, concrete, or other durable materials.
	Unpaved Roads	Roads made of gravel, dirt, or other loose materials, often found in rural areas.
By Administrative Classification	National Roads	Major roads maintained by the national government, connecting cities and regions.
	Provincial Roads	Roads maintained by regional or provincial authorities.
	Municipal Roads	Roads maintained by local governments for urban and suburban connectivity.
	Private Roads	Roads maintained by private entities, such as those in gated communities or industries.
By Traffic Volume	High-Traffic Roads	Roads designed to handle a large number of vehicles daily, typically highways.
	Low-Traffic Roads	Roads with low vehicle frequency, often found in rural or residential areas.

Roads in Algeria were classified according to SETRA 1989 (i.e. *Service d'Etudes Techniques des Routes et Autoroute*) into five functional categories, corresponding to the economic and administrative purposes assigned by territorial planning policies. The categories are defined in the following Table I.3.

Table I.3. Road Categories in Algeria. *Source:* SETRA (1989)

Category of roads	Definition and attribution
1	Connection between major economic centers and heavy industrial centers, and links providing access from industrial and processing centers to the primary network mentioned above.
2	Connections between processing industry hubs and links connecting diversified light industry hubs with the previous network.
3	Connections between district capitals and provincial capitals not served by the previous network, with the category 1 and 2 network.
4	Connections for all living centers not linked to the category 1-2 and 3 networks, with their district capital and with the previous network.
5	Roads and tracks not included in the previous categories.

1.9. Roads terminology

In road construction, designing and planning a road involves several crucial elements that ensure functionality, safety, and longevity. Among the most important aspects of this design process are the cross-section profile, longitudinal profile, and plan profile layout, which together provide a comprehensive understanding of the road's geometry and alignment. These profiles and layouts are essential tools for engineers and planners to visualize the road's construction, evaluate its interaction with the surrounding environment, and ensure that it meets safety, operational, and maintenance standards.

The geometric characteristics of road profiles are influenced by a range of factors such as topography, traffic volume, safety considerations, climate, environmental impact, construction materials, and budget constraints. The natural landscape, such as hills or valleys, dictates the road's elevation changes and alignment, while traffic demands determine the road's width, lane configuration, and load-bearing capacity. Safety features, such as curve radii and slope gradients, are designed to ensure smooth traffic flow and minimize accidents.

Additionally, climate conditions affect drainage and material selection, and environmental regulations may limit the road's footprint or require specific alignments. Lastly, the integration of utilities and infrastructure into the road design is critical, especially in urban areas, to minimize disruption and ensure functional connectivity. Together, these factors must be balanced to ensure the road is safe, efficient, durable, and cost-effective.

I.9.1. Cross-section profile

The cross-section profile primarily illustrates the width of the pavement and the shoulders. Is a vertical slice of the road taken perpendicular to its centerline, showing the arrangement and dimensions of various components. It illustrates the road's width, including the pavement, shoulders, and any adjacent features such as ditches or berms. The cross-section profile details the road's shape. This profile is crucial for ensuring proper drainage, vehicle stability, and overall road safety. It also indicates the cross slopes (Figures I.27 and I.28).

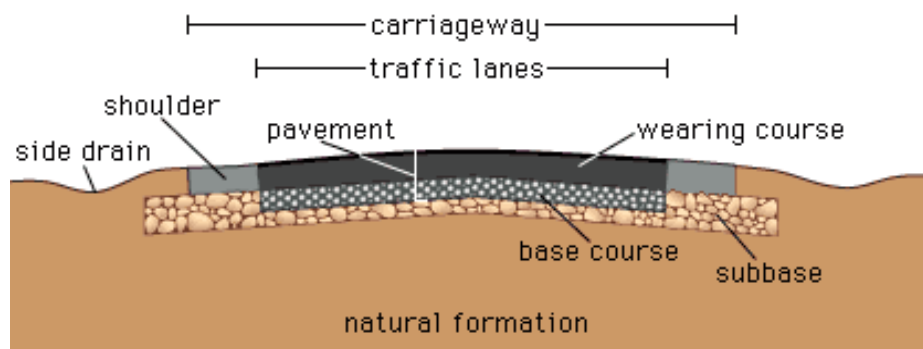

Figure I.27. Schematic cross section of a modern roadway. *Source:* <https://www.britannica.com/technology/road/The-modern-road>

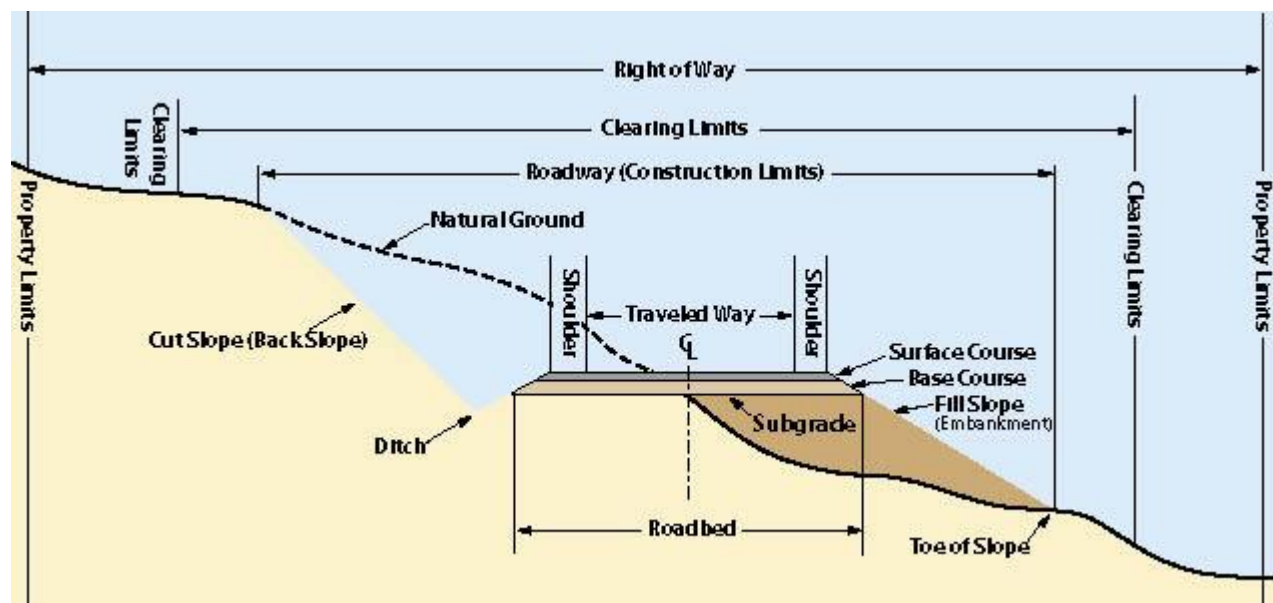

Figure I.28. Terms used to define roads cross-section. *Source:* http://www.nativerivevegetation.org/learn/manual/ch_3.aspx

Some common terms are used to define roads cross-section as shown in the caption of Figure I.27 and I.28, as follows:

- **Roadway:** The portion of land that belongs to the community and is designated for the road and its dependencies.
- **Roadbed:** The actual surface area of the land occupied by the road.
- **Platform:** The road surface that includes the pavement and the shoulders.
- **Pavement:** The prepared surface of the road on which vehicles travel.
- **Shoulders:** The lateral areas of the platform that border the pavement externally.
- **Safety berm:** An unpaved safety margin.
- **Ditch:** A trench excavated in the ground.

I.9.2. Longitudinal profile

The longitudinal profile in road construction is a vertical section along the centerline of a road, showing the variation in elevation over its length. It represents the road's gradient, slopes, and vertical alignment, helping engineers design smooth and safe roads. The profile includes details such as existing ground levels, proposed road levels, grades, cut-and-fill sections, and drainage considerations. It is essential for ensuring proper drainage, ride comfort, and structural stability, particularly in hilly or undulating terrains. It indicates the values of slopes and gradients (Figure I.29), as well as the radii of hilltops and low points. It follows the vertical plane passing through the centerline of the road alignment.

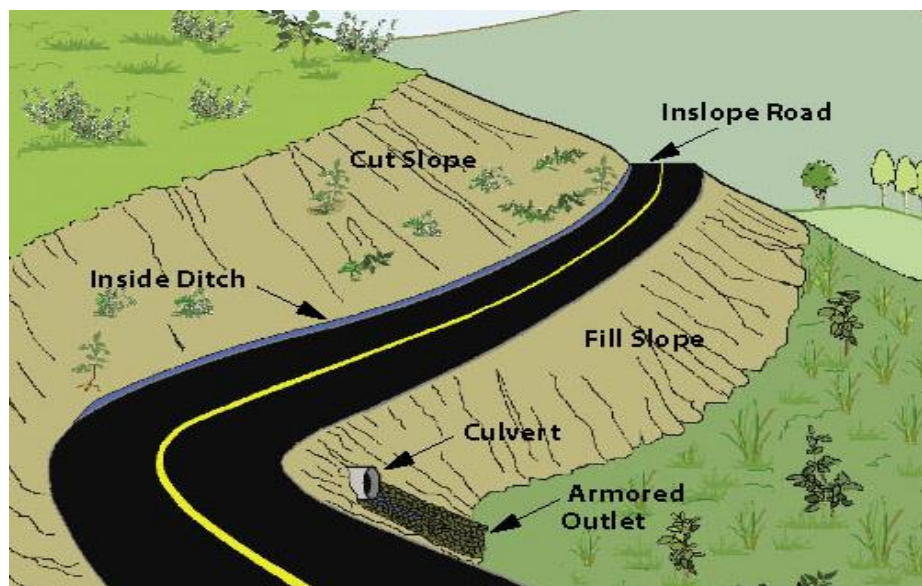

Figure I.29. Terms used to define roads longitudinal profile. *Source:* http://www.nativervegetation.org/learn/manual/ch_3.aspx

I.9.3. Plan profile

The plan profile layout in a route refers to the horizontal representation of a road or route, showing the alignment and geometry of the road as viewed from above. This layout includes:

- **Straight sections:** The lengths of straight portions of the road.
- **Curves:** The radii and lengths of curves or bends in the road.
- **Intersections:** The design and layout of intersections with other roads or pathways.
- **Transitions:** The areas where the road changes from a straight section to a curve or vice versa.
- **Landmarks and Features:** Notable features along the road, such as bridges, tunnels, or significant geographic elements.

The plan profile provides a detailed view of the road's alignment and is essential for planning, designing, and analyzing road infrastructure to ensure it ensures traffic needs and environmental considerations, as shown in Figure I.30.

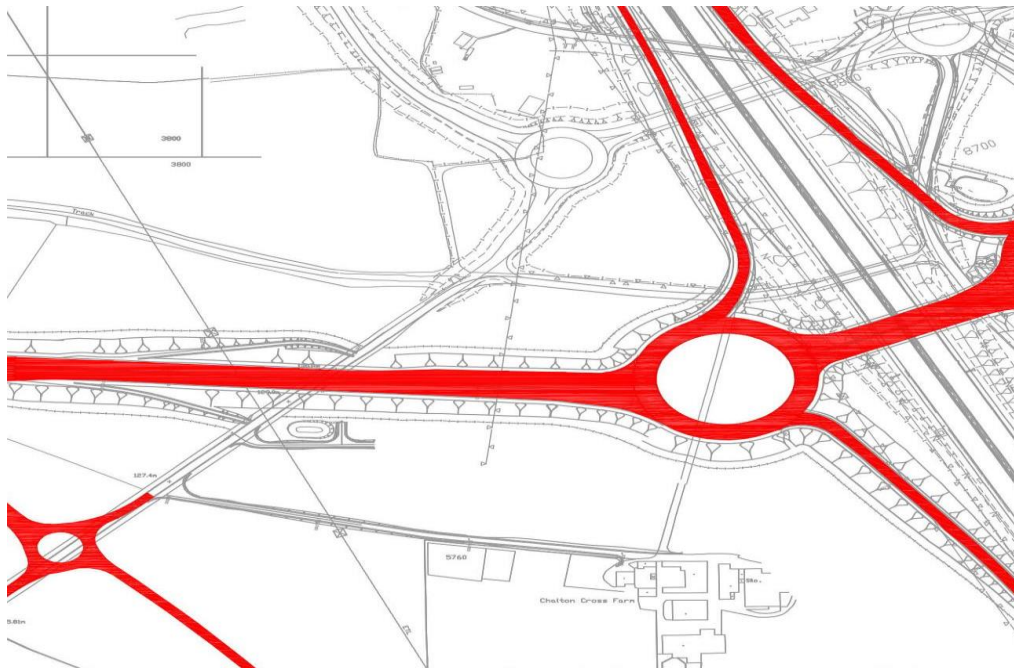

Figure I.30. Example of defined plane road profile. *Source:* <https://www.tppweb.co.uk/expertise/highway-design/>

I.10. Conclusion

Roads and pavements are fundamental elements of modern infrastructure, serving as critical arteries for transportation, trade, and connectivity. The study of roads and pavement construction encompasses an understanding of their design, material selection, load-bearing capacities, and maintenance requirements.

A well-constructed pavement system ensures durability, safety, and cost-efficiency, meeting both the functional and structural demands imposed by traffic and environmental factors. The choice of materials—ranging from bitumen and concrete to aggregates and subgrade soil—plays a pivotal role in achieving the desired performance and longevity of roadways.

Furthermore, the classification of roads based on function, surface type, access control, and traffic volume highlights the diversity of roadway needs and the tailored approaches required for their development. Pavement systems, whether flexible or rigid, are meticulously designed to distribute vehicular loads, resist environmental stresses, and provide a comfortable and secure driving experience.

As urbanization and global mobility increase, advancements in road engineering, sustainable material usage, and innovative construction techniques will continue to be critical in addressing future challenges. This chapter underscores the intricate balance between technical precision, environmental considerations, and economic feasibility in the planning and development of roads and pavements, ensuring their vital role in fostering societal progress.

Accordingly, the next chapter investigates the vehicle kinematic and the design methods of pavement in order to better master the reaction of roadways to the loads caused by the users and to choose the adequate materials to ensure long service life of the road.

Chapter II: Vehicle Kinematics

II.1. Introduction

Vehicle kinematics is the study of vehicle movements, focusing mainly on trajectory and dynamics without delving into the details of the forces and moments causing these movements. In other words, vehicle kinematics analyzes how vehicles move through space, considering the various parameters that influence their movement, namely:

- **Trajectory and position:** Kinematic examines how a vehicle moves relative to a fixed coordinate system. This includes studying the trajectory, which is the path followed by the vehicle, and the vehicle's position at any given time.
- **Speed and acceleration:** Speed is the rate at which a vehicle changes position, while acceleration describes the change in speed. Vehicle kinematics analyzes how these two parameters vary over time and influence the overall movement.
- **Steering angles:** This includes the angles of the wheels, which affect the vehicle's direction. Specifically, kinematics studies the relationships between these angles and the curvature of the vehicle's trajectory.
- **Kinematic derivatives:** The study of the derivatives of movement parameters (speed and acceleration) is also crucial. For example, the derivative of speed with respect to time is acceleration, and the derivative of acceleration with respect to time is the change in acceleration.
- **Kinematic models:** Models such as the bicycle model (which simplifies a vehicle to a single front and rear axis) are often used to analyze and predict vehicle behavior in terms of direction and stability.
- **Simulation and analysis:** Vehicle kinematics often uses computer simulations to analyze vehicle movements in various scenarios, such as turns, lane changes, or avoidance maneuvers.

The study of kinematics is essential for the development and improvement of autonomous driving systems, suspension system design, and the development of traction and stability control systems.

II.2. Mechanical aspect notice

Vehicle kinematics refers to the study of vehicle movements without considering the forces that cause these movements. To understand kinematics, it is essential to know a few key concepts described below.

II.2.1. Trajectory

The trajectory of a point in a system is the set of successive positions taken by that point during the movement of the system to which it belongs. The trajectory depends on the chosen reference frame. In the same system, two points may not necessarily have the same trajectory.

- If the set of points forms a straight line, the trajectory is linear.
- If the set of points forms a circle, the trajectory is circular.

The trajectory is the path followed by the vehicle. For combined movements (e.g., a curve with acceleration), the trajectory can be complex and requires detailed calculations. When the vehicle turns, the dynamics of the turn are influenced by speed, curve radius, and centrifugal force. The relation to keep the vehicle in a curve is: The centrifugal force must be balanced by the friction force between the tires and the road.

Speed and acceleration are essential parameters for describing a vehicle's movement. Speed can be calculated at any moment if acceleration and time elapsed since the start of the movement are known. Although not strictly kinematics, dynamics is often studied together, as it deals with the forces involved (such as friction, gravity, and tensile forces) and their effects on vehicle kinematics.

For a complete understanding, it is important to study vehicle kinematics in detail in the sections below.

II.2.2. Rectilinear motion

If a vehicle moves in a straight line (see Figure II.1), it is referred to as rectilinear motion. This movement can then be described by parameters such as speed (v) and acceleration (a). The basic relationships are :

$$v = u + at \quad (\text{II.1})$$

$$s = ut + \frac{1}{2}at^2 \quad (\text{II.2})$$

$$v^2 = u^2 + 2as \quad (\text{II.3})$$

Where (u) is the initial velocity, (s) is the displacement, and (t) is the time.



Figure II.1. Vehicle in a rectilinear motion. *Source:* <http://pccollege.fr/cycle-4/cycle-4-classe-de-4eme/chapitre-v-mouvements-et-vitesse/>

II.2.3. Circular motion

When a vehicle turns, it follows a circular motion (see Figure II.2). In this type of motion, the linear velocity remains constant in magnitude but not in direction. Since the velocity vector is by definition tangent to the trajectory, which is circular in this case, it constantly changes direction. Thus, a point moving along such a trajectory at a constant speed still undergoes acceleration. This acceleration, which is always directed towards the center of the circle around which it is turning, is called centripetal acceleration. It allows the body to maintain its circular path.

The concept of circular motion is part of point mechanics. In solid mechanics, one must distinguish between:

- Rotational motion, where the solid rotates around a point (the points of the solid describe concentric circles).
- Circular translation motion, where all points of the solid describe circles of the same radius but with different centers, such as the gondolas on a Ferris wheel.
- Radius of curvature (R): The distance from the center of the curve to the vehicle.
- Angular velocity (ω): The rate at which the angle changes.
- Centripetal acceleration (\mathbf{a}_c): Acceleration towards the center of the curve.
- Initial position (θ_0): The position of the vehicle at the static state.

Considering the case of uniform circular motion in the (x, y) coordinate system, let's consider a material point M with a center $O(0, 0)$ and a radius R . We can thus derive the expression for the angle formed by the vector \overrightarrow{OM} and the (Ox) axis as a function of time:

$$\theta(t) = \omega t + \theta_0 \quad (\text{II.4})$$

Where θ_0 is the initial angle. Consequently, we can deduce the coordinates of point M as a function of time, as follows:

$$\begin{aligned} x_M(t) &= R \cdot \cos(\omega t + \theta_0) \\ y_M(t) &= R \cdot \sin(\omega t + \theta_0) \end{aligned} \quad (\text{II.5})$$

Then, we can deduce the components of the acceleration vector \vec{a} as follows:

$$a_x(t) = -R\omega^2 \cdot \cos(\omega t + \theta_0) \quad (\text{II.6})$$

$$a_y(t) = -R\omega^2 \cdot \sin(\omega t + \theta_0)$$

In terms of the vector \overrightarrow{OM} , the expression for the acceleration vector can be written as follows:

$$\vec{a}_c = -\omega^2 \overrightarrow{OM} \quad (\text{II.7})$$

We note that the tangential acceleration (a_t) is null, and the normal acceleration (a_c), also known as centripetal acceleration, is equal to the magnitude of \vec{a} ; therefore:

$$a_t = 0 \quad (\text{II.8})$$

$$a_c = \|\vec{a}\| = \sqrt{(-R\omega^2 \cdot \cos(\omega t + \theta_0))^2 + (-R\omega^2 \cdot \sin(\omega t + \theta_0))^2} = R\omega^2 \quad (\text{II.9})$$

In addition, the velocity can be expressed us function of the time period (T) as follows:

$$v = \frac{2\pi R}{T} \quad (\text{II.10})$$

Indeed, the expression for angular velocity (ω) is given by Eq.II.11:

$$\omega = \frac{2\pi}{T} = \frac{v}{R} \quad (\text{II.11})$$

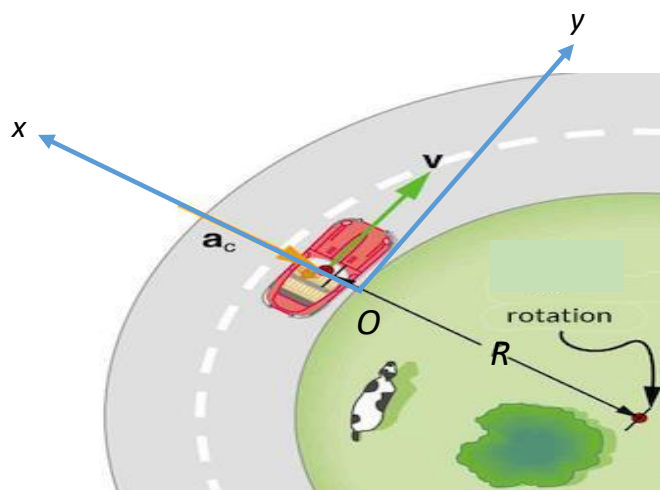

Figure II.2. Vehicle in circular motion. *Source: Khan Academy & Openstax College Physics*
<https://fr.khanacademy.org/science/physique-a-l-ecole/>

By substituting equation II.11 into equation II.9, we obtain the final expression for the centripetal acceleration of a vehicle in circular motion.

$$a_c = R\omega^2 = R\left(\frac{v}{R}\right)^2 = \frac{v^2}{R} \quad (\text{II.12})$$

II.3. Isolated vehicle

To understand a vehicle's performance in terms of safety and dynamic behavior, it is crucial to grasp the concepts related to engine effort, braking grip, and stopping distance. Here is an overview of each of these elements:

II.3.1. Engine effort

Engine effort, or engine power, plays a key role in a vehicle's performance. It determines the vehicle's ability to accelerate and maintain speed. This effort is typically measured in horsepower (HP) or kilowatts (kW).

- **Engine power:** Engine power, often measured in HP or kW, affects the vehicle's acceleration capacity. Higher is the engine power, faster the vehicle can accelerate.
- **Engine torque:** Torque, measured in Newton-meters (Nm), is the rotational force produced by the engine. It is essential for initial accelerations and power climbs.
- **Effort management:** Engine effort is controlled by the accelerator, and modern engine management systems can adjust power according to vehicle load, and driving conditions.

The effect of an axle consisting of multiple wheels is not simply the sum of the isolated wheels as shown in Figure II.3. Similarly, the use of single tires instead of duals or new types of suspensions influences the calculation of equivalent traffic loads.

To account for these phenomena, correction factors are applied to the power law. The Organization for Economic Co-operation and Development (OECD) has proposed a formula defining mechanical damage with coefficients that consider factors related to vehicle technology and configuration.

$$D_i = \left(k_1 k_2 k_3 \frac{P_i}{P_{ref}}\right)^\alpha \quad (\text{II.13})$$

- D_i = damage caused by an axle to the road (according to the OECD definition)
- P_i = total load of axle
- P_{ref} = load of the standard axle
- k_1 = coefficient for axle type
- k_2 = coefficient for tire type
- k_3 = coefficient for suspension type
- α = load coefficient, also called "power"

The factors involved in this formula depend on the type of structure for which the traffic needs to be calculated. For flexible structures and for axle spacing of tandem and tridem axles ranging between 1.35 and 1.50 meters, the following values in Table II.1 are proposed.

Table II.1. Factors Involved in Vehicle Technology According to OECD

Factors	Characteristics	Values
α	Power	4
k1	Single axle	1.0
k1	Tandem axle	0.6
k1	Tridem axle	0.45
k2	Standard dual wheels	1.0
k2	Standard single wheels	1.3
k2	Super-wide single wheels	1.2
k3	Traditional suspensions	1.0
k3	Air suspensions	0.95

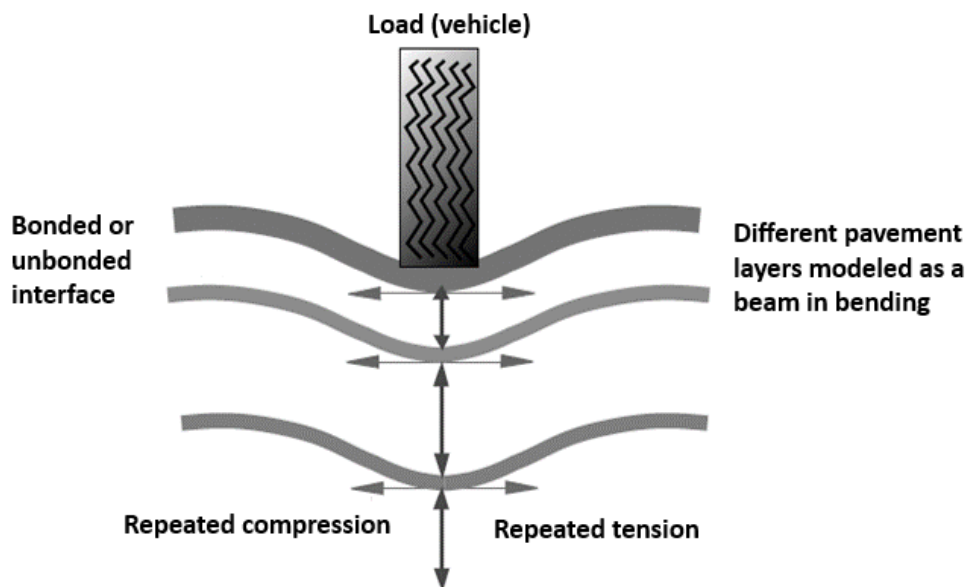

Figure II.3. Engine effect of a vehicle axle on the pavement. Source: <https://fr.wikipedia.org/>

II.3.2. Braking traction

Braking traction is the ability of the tires to maintain sufficient contact with the pavement to stop the vehicle safely. Several factors influence braking traction:

- **Friction coefficient:** This represents the ability of the tires to generate a friction force with the road. A higher friction coefficient allows for better stopping power. It depends on the type of tires and road conditions (wet, dry, slippery).
- **Tire wear:** Worn or improperly inflated tires will have a lower friction coefficient, reducing braking efficiency.
- **Road conditions:** The quality of the road surface (e.g., gravel, asphalt, snow) directly affects tire traction.

Factors influencing stopping distance can be listed as follows:

- **Vehicle speed:** Higher is the speed, longer is the stopping distance.
- **Vehicle weight:** The weight of the vehicle is also a determining factor. Kinetic energy means that heavier is the vehicle, longer is the stopping distance. Stopping distance is proportional to the mass.
- **Pavement traction:** The level of pavement traction is determined by the weather. Stopping distance will differ in dry weather, rainy weather, or in the case of ice or snow. On wet surfaces, tire traction is reduced by half. This is why speed limits are lowered when it rains. On highways, the speed limit is reduced to 100 km/h (instead of 110 km/h) and 110 km/h (instead of 130 km/h) on the motorway (i.e. Figure II.4).
- **Vehicle conditions:** The condition of the vehicle, particularly the tires and braking system, will influence stopping distance. Tires, brake pads, or suspensions in poor condition will affect vehicle traction and thus increase stopping distance.

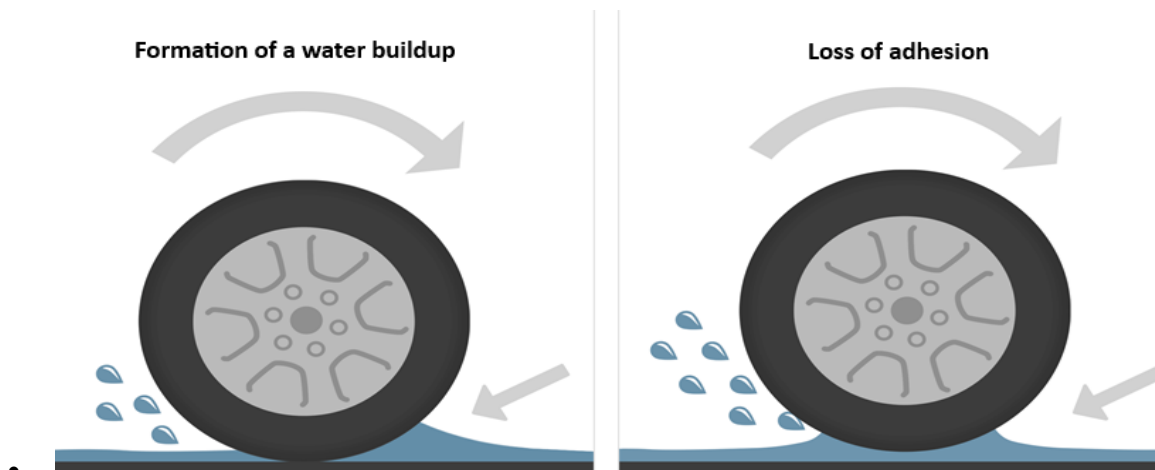

Figure II.4. Loss of traction during the braking of a moving vehicle. *Source:* <https://www.daparto.fr/info/aquaplaning-fr/>

II.3.3. The stopping distance

The stopping distance is the total distance required for a vehicle to come to a complete stop after the driver starts braking. It consists of two parts:

- **Reaction distance:** This is the traveled distance during the driver's reaction time, which is the time between perceiving the need to brake and the moment the driver actually starts applying the brakes. It depends on the vehicle's speed and the driver's reaction time.
- **Braking distance:** This is the required distance to stop the vehicle once the brakes are applied. It depends on the vehicle's initial speed, tire traction, and braking power.

II.3.3.1. Braking distance

The braking distance is the distance traveled between the moment the driver presses the brake pedal and the moment the vehicle is fully stopped. To calculate the braking distance, subtract the reaction distance from the stopping distance.

At 50 km/h, on a dry road, the reaction distance is 15 meters and the stopping distance is 25 meters. Therefore, the braking distance will be: $25 - 15 = 10$ meters. Note that on a wet road, the braking distance is multiplied by 2.

The braking distance can be calculated with the formula:

$$d_b = \frac{v^2}{2.a} \quad (\text{II.14})$$

With:

- d_b : braking distance,
- v : initial speed of the vehicle (in meters per second, m/s),
- a : average deceleration (in meters per second squared, m/s^2).

For example, if a vehicle is traveling at 100 km/h (27.8 m/s) and the deceleration due to braking is 7 m/s^2 , the braking distance is 56.2 meters.

II.3.3.2. Reaction time

It is estimated that the reaction time is about 1 to 2 seconds for a driver in a good physical condition. The distance traveled during the reaction time is proportional to the reaction time. This means that faster is the driver's reaction, shorter is the reaction distance. Reaction time can be increased due to alcohol consumption, drug use, or medication. The driver's fatigue also impacts reaction time.

According to (ASSTHO, 2012), the distance traveled in 1 second is three times the tens digit of the speed. For example, at 50 km/h, the calculation is: $5 \times 3 = 15$ meters, so the distance traveled during the reaction time is 15 meters.

The total stopping distance (d_s) is the sum of the distance traveled during the reaction time (d_r) and the braking distance (d_b), as shown in Figure II.5. It can be expressed as:

$$d_s = d_r + d_b \quad (\text{II.15})$$

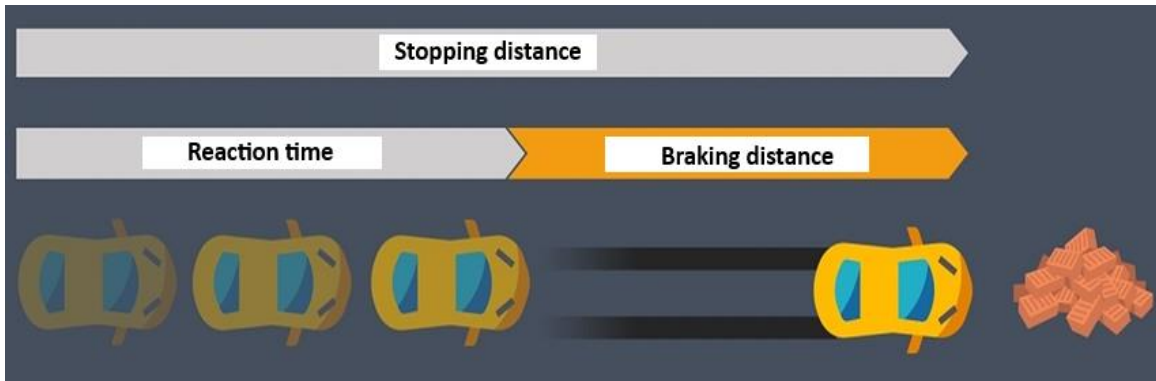

Figure II.5. The stopping distance required for a vehicle to come to a complete stop.

Source: <https://www.codeenpoche.fr/cours-de-code/le-conducteur/distance-freinage/>

II.3.4 Vehicle stability

Vehicle stability in kinematics is a crucial aspect of vehicle dynamics, concerning how the vehicle reacts to forces and movements to maintain balance and control. In kinematics, stability often refers to how the vehicle behaves under different driving conditions and how its movements can be predicted and controlled to avoid dangerous situations. Figure II.6 illustrates the stability forces of a moving vehicle.

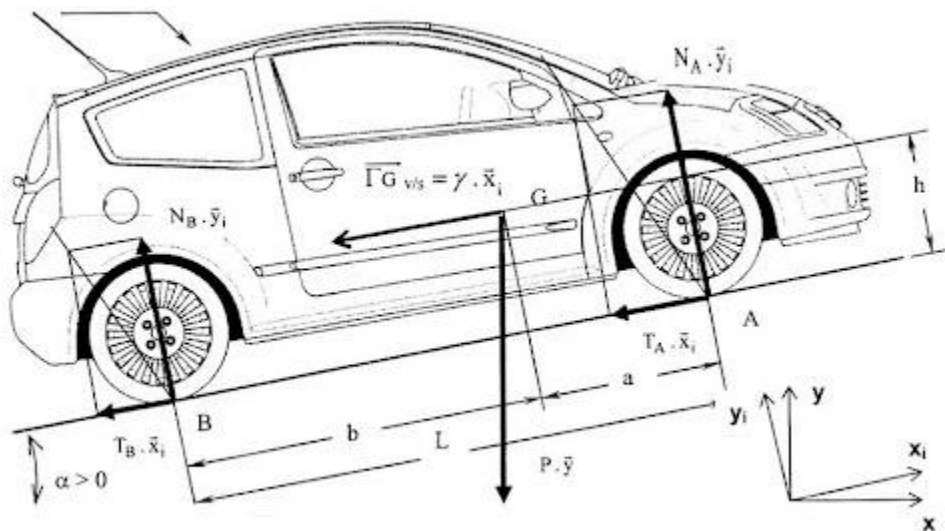

Figure II.6. Stability forces of a moving vehicle. Source :

<http://www.educauto.org/ressources-mediatheque/equilibre-mecanique-vehicule>

II.3.4.1. Center of gravity

The center of gravity (CG) of the vehicle is the point where the vehicle's mass is concentrated. The position of the CG strongly influences vehicle stability:

- **Height of the CG:** A higher CG can make the vehicle more prone to tipping over, especially during sharp turns or sudden maneuvers. A lower CG generally improves stability by reducing the risk of overturning.
- **Position of the CG:** The CG should be well-positioned relative to the vehicle's longitudinal axis. A significant offset can affect the vehicle's balance, particularly during turns.

II.3.4.2. Steering angle and turning radius

The steering angle of the front wheels affects the direction of the vehicle and the turning radius of the trajectory:

- **Steering angle:** A larger steering angle results a shorter turning radius, allowing for tighter turns. However, excessive steering can reduce stability, especially at high speeds.
- **Turning radius:** The turning radius of the trajectory is important for stability. A radius that is too small at high speeds can lead to skidding or loss of control.

II.3.4.3. Load distribution

The distribution of loads between the front and rear axles impacts vehicle stability:

- **Weight distribution:** An even distribution of weight between the front and rear improves stability. Excess weight on one axle can lead to uneven tire wear and affect handling.
- **Load transfer:** During sudden braking or acceleration, load transfer can alter the distribution of forces and affect stability. The vehicle may become unstable if load transfer is not properly managed.

II.3.4.4. Cornering behavior

Stability in corners is an essential aspect of vehicle kinematics:

- **Understeer:** When the front of the vehicle loses traction and fails to follow the desired path, it is called understeer. This can be corrected by adjusting steering or reducing speed.
- **Oversteer:** When the rear of the vehicle loses traction and drifts toward the outside of the turn, it is called oversteer. This may require steering correction to avoid skidding.

II.3.4.5. Effect of speed

The vehicle's speed plays a crucial role in stability:

- **High speed:** At high speeds, centrifugal forces increase, which can reduce stability, especially during turns or sudden maneuvers.

- **Low speed:** At low speeds, the vehicle is generally more stable, but reckless maneuvers can still cause problems.

II.3.4.6. Driver assistance systems

Many modern vehicles are equipped with driver assistance systems that enhance stability:

- **Traction control:** Helps maintain traction of the driven wheels and prevent skidding.
- **Stability control:** Automatically corrects deviations from the intended trajectory by applying brakes or adjusting engine power.
- **Brake assistance:** Enhances braking performance to avoid collisions or improve stability during emergency braking.

II.4. Grouped vehicles

Grouped vehicles in motion are collections of vehicles traveling together on a road. This can include truck convoys, groups of cyclists, clusters of cars, or even automated driving systems. Some key aspects to consider regarding grouped vehicles in motion are listed as follows:

II.4.1. Safety distance

The safety distance between vehicles is a crucial concept for safe driving. It represents the distance to maintain between your vehicle and the one in front of you to allow for a safe stop in case of sudden braking. The safety distance is influenced by several factors, including speed, weather conditions, road conditions, and the braking capabilities of the vehicles.

To approximately estimate the overtaking distance (D) based on speed, general rules can be used considering the speed at which you are traveling and the speed of the vehicle you are overtaking. Here's a simplified method to calculate this distance:

- Overtaking speed (V_d): The speed at which you wish to overtake the vehicle.
- Speed of the vehicle to be overtaken (V_e): The speed of the vehicle you are overtaking.

In general, a basic rule for driving is that the overtaking distance should be sufficient to allow for a safe overtaking maneuver, usually by adding a safety margin. Here is a simplified approach for an approximate calculation:

$$D \approx \frac{2(V_d + V_e)}{a \cdot F} \quad (\text{II.16})$$

- (a) Acceleration: The ability to accelerate during overtaking, approximately 2 m/s^2 (in reality, this may vary).
- (F) Safety Factor: A factor to ensure a safety margin, typically between 1.5 and 2.

When two vehicles are following each other, the driver of the second vehicle must maintain a sufficient safety distance to avoid a collision in case of sudden deceleration or abrupt stop of the vehicle in front. This distance is greater as speed increases. It corresponds to the distance traveled by the vehicle during a delay of at least two seconds, according to Article R412-12 of the French Road Code, as shown in Figure II.7.

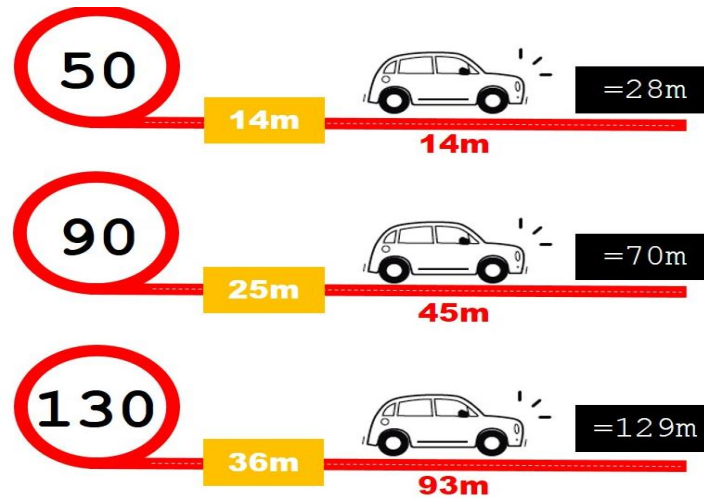

Figure II.7. Safe distances according to the French road code. *Source :* <https://www.prostagespermis.fr/p-distance-de-securite>

II.4.2. Overtaking distance

The overtaking distance is the distance required to safely perform an overtaking maneuver on the road. This distance depends on several factors, including the speed of the vehicle, traffic conditions, visibility, and road characteristics. A detailed explanation of this concept and influencing factors is provided below:

- **Vehicle speeds:** The relative speed between the overtaking vehicle and the one being overtaken directly influences the distance needed to complete the maneuver. The faster the vehicles are traveling, the greater the required distance.
- **Visibility:** Good visibility is essential for a safe overtaking. The required distance increases if visibility is reduced (e.g., in curves, uphill, or adverse weather conditions).
- **Road conditions:** The nature of the road (straight or curved, uphill or downhill, road surface) also impacts the required distance. On a winding or uphill road, the overtaking distance increases.
- **Length of the vehicle being overtaken:** The longer the vehicle being overtaken, the greater the distance needed to complete the maneuver.
- **Vehicle performance:** The performance of the overtaking vehicle (engine power, acceleration) plays a crucial role. A more powerful vehicle can overtake more quickly and therefore require a shorter distance.

II.4.2.1. Approximate calculation of overtaking distance

There is no precise universal formula to calculate the overtaking distance (D_o) as it varies based on the factors mentioned above. However, a simplified calculation method can be used to give a general idea.

To calculate the approximate overtaking distance, it is useful to know certain parameters, such as the speed of the vehicle, the speed of the other vehicle (if there is one), and the driving conditions. Here is a simplified method to estimate the distance needed for overtaking based on speed:

$$D_o \approx \frac{V_d(V_d - V_e)}{2a} \quad (\text{II.17})$$

For more clarity, Figure II.8 illustrates an example of the required overtaking distance according to MTP (2001).



Figure II.8. Example of the required overtaking distance. *Source:* <https://www.ornikar.com/code/cours/circulation/croisements-depassesments>

II.5. Conclusion

Vehicle kinematics, the study of motion without considering the forces causing it, plays a crucial role in understanding and improving driving dynamics. By analyzing how vehicles move—both in terms of trajectory and interaction with road surfaces—engineers and designers can optimize vehicle handling, stability, and safety. Effective kinematic design ensures that vehicles respond predictably to driver inputs and environmental conditions, enhancing overall driving comfort and safety.

Understanding vehicle kinematics is essential for developing advanced driver assistance systems and for ensuring that vehicles perform reliably under a range of driving scenarios. Therefore, the subsequent chapter examines the pavement design methods.

Chapter III: Road Pavement Design

III.1. Introduction

Road pavement design is a critical component of road engineering that focuses on creating a durable, smooth, and efficient surface for vehicular traffic. Pavement design ensures that the road can withstand traffic loads, environmental factors, and long-term wear while providing a safe and comfortable driving experience. The process involves selecting appropriate materials, determining layer thickness, and ensuring proper structural integrity to support varying levels of traffic volume and load-bearing requirements. Pavement design takes into account factors such as soil conditions, climate, expected traffic patterns, and local environmental conditions, as well as considerations for water drainage, maintenance, and cost-effectiveness. The goal is to design a pavement structure that is both sustainable and cost-efficient, minimizing maintenance needs and maximizing service life.

A key element of pavement design is selecting the appropriate type of pavement—such as flexible, rigid, or composite pavement—based on the road's intended use and traffic conditions. In addition to material selection, the design must include calculations to determine the correct thickness and layering of materials, such as subbase, base course, and surface layers, to ensure the pavement can bear the anticipated loads. Factors like traffic intensity, climate, and soil characteristics play a significant role in determining the ideal pavement structure. Furthermore, the pavement must be designed with adequate drainage systems to prevent water damage, which can lead to pavement failure. Ultimately, effective road pavement design not only extends the lifespan of the roadway but also contributes to reducing maintenance costs and improving overall road performance.

III.2. Parameters for pavement design

This section focuses on the essential factors that influence the structural design and performance of road pavements. In this section, we explore the critical parameters that engineers must consider when designing a pavement system that can withstand traffic loads, environmental stresses, and long-term usage. Pavement design is a complex process that involves a detailed understanding of materials, traffic patterns, subgrade conditions, climate, and drainage systems. Each of these factors is essential in determining the type, thickness, and overall structure of the pavement layers. By accurately assessing these parameters, engineers can design pavements that provide optimal performance, durability, and cost-efficiency while minimizing the need for frequent maintenance.

Key parameters for pavement design include the anticipated traffic loads (both in terms of volume and axle load distribution), the subgrade soil properties (such as strength, compaction, and moisture content), and the climatic conditions that may affect material performance, including temperature fluctuations and precipitation. Additionally, considerations for drainage, material characteristics, and maintenance requirements are integral to ensuring the pavement's long-term stability and functionality. This section provides a comprehensive overview of these parameters, explaining how each factor contributes to the design process and the methods used to assess them accurately.

III.2.1. Traffic

Traffic significantly influences pavement design parameters, as it determines the load-bearing requirements and durability needs of the pavement structure. Factors such as traffic volume, axle load distribution, and vehicle types impact material selection, layer thickness, and overall structural design. Heavy and frequent traffic can accelerate deterioration, necessitating stronger materials and advanced engineering techniques to enhance pavement longevity and performance. Proper traffic analysis ensures that pavements are designed to withstand anticipated loads, reducing maintenance costs and improving safety.

III.2.2. Climate and environment

Climate and environmental factors significantly influence pavement design by affecting material behavior, structural integrity, and long-term durability. Temperature fluctuations cause thermal expansion and contraction, leading to cracks, rutting, and fatigue failure, especially in regions with extreme seasonal variations. Freeze-thaw cycles can accelerate pavement deterioration as water infiltrates cracks, freezes, and expands, weakening the structure over time. High temperatures and prolonged UV exposure contribute to asphalt softening, oxidation, and surface aging, reducing pavement lifespan. Moisture is another critical factor, as excessive rainfall, poor drainage, and high groundwater levels can weaken the subgrade, leading to differential settlement, potholes, and loss of structural support. In coastal areas, saltwater intrusion can accelerate corrosion in reinforced concrete pavements, further compromising structural integrity. Wind erosion and dust accumulation in arid regions can also affect surface texture and skid resistance. To mitigate these environmental effects, engineers must carefully select materials, incorporate proper drainage solutions, apply protective coatings, and design pavements with climate-adaptive strategies. By accounting for these factors, pavement designs can be optimized for resilience, reducing maintenance costs and ensuring long-term functionality under diverse environmental conditions.

Precipitation and drainage conditions directly impact the moisture content of the supporting soil, influencing its bearing capacity and the feasibility of reusing excavation materials as fill. Temperature effects are more complex, as variations occur at different rates due to daily and seasonal cycles. These fluctuations affect pavement materials in two key ways: altering the material's modulus and generating stress fields and deformations due to thermal expansion

and contraction. For instance, as pavement cools, it contracts, but restricted longitudinal movement induces tensile stress, potentially leading to transverse cracking that propagates through thermal cycles (Figure III.9). When a base layer treated with hydraulic binders is considered, thermal and curing shrinkage can cause additional cracking in the bituminous layer due to friction at the interface (Figure III.9).

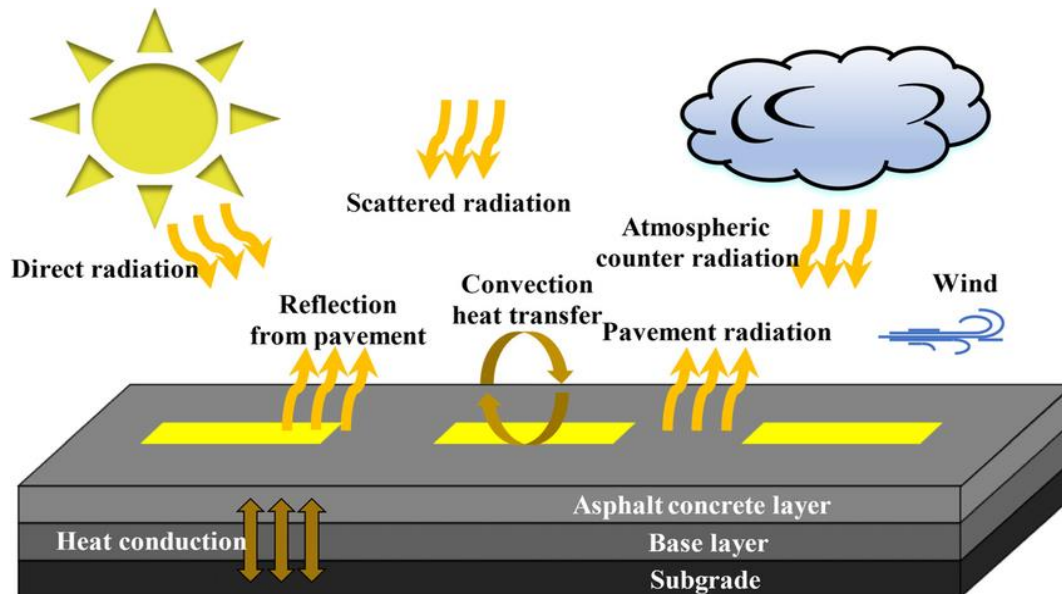

Figure III.1. Pavement behavior under thermal and environmental conditions. *Source:* (Gong Z, 2023) [10.1186/s43065-022-00054-5](https://doi.org/10.1186/s43065-022-00054-5)

III.2.3. The supporting soil

The supporting soil directly affects the structural stability, load-bearing capacity, and overall performance of the pavement system. Soil properties such as strength, compaction, moisture content, and susceptibility to settlement determine the required pavement thickness and material selection. Weak or highly compressible soils may require stabilization techniques, such as soil replacement, chemical treatment, or geosynthetic reinforcement, to enhance their bearing capacity and prevent excessive deformation. Additionally, variations in soil type and drainage conditions influence the risk of differential settlement and frost heave, which can lead to cracks and surface irregularities. Proper evaluation and improvement of the subgrade ensure a durable and resilient pavement structure, reducing maintenance needs and extending service life.

III.2.4. Structure type and materials

The type of pavement structure and the used materials directly influence load distribution, durability, and maintenance requirements. Pavements are generally classified as flexible or rigid, with each requiring different design considerations. Flexible pavements, typically made of asphalt layers, distribute loads over a broader area but are more susceptible to deformation under heavy traffic and temperature changes. Rigid pavements, constructed

with concrete, offer higher load-bearing capacity and durability but require careful joint design to accommodate thermal expansion and contraction. The choice of materials, including asphalt mixtures, concrete compositions, and subbase aggregates, affects properties such as strength, flexibility, resistance to moisture, and susceptibility to environmental factors. Proper selection of structure type and materials ensures optimal pavement performance, longevity, and cost-effectiveness under specific traffic and climate conditions.

III.2.5. Construction and maintenance

Construction and maintenance practices significantly impact pavement design parameters, as they determine the pavement's durability, performance, and long-term cost-effectiveness. Proper construction techniques, including material selection, layer compaction, and quality control, ensure that the pavement meets design specifications and can withstand expected traffic loads and environmental conditions. Poor construction practices, such as inadequate compaction or improper drainage installation, can lead to premature failures like rutting, cracking, and settlement. Similarly, maintenance strategies play a vital role in extending pavement life by addressing issues like surface wear, moisture infiltration, and structural deterioration. Regular inspections, timely repairs, and preventive measures, such as sealing cracks and resurfacing, help maintain pavement integrity and reduce costly reconstruction. A recapitulation of the parameters influencing the pavement design according to (Younos *et al*, 2020) is provided in Figure III.2

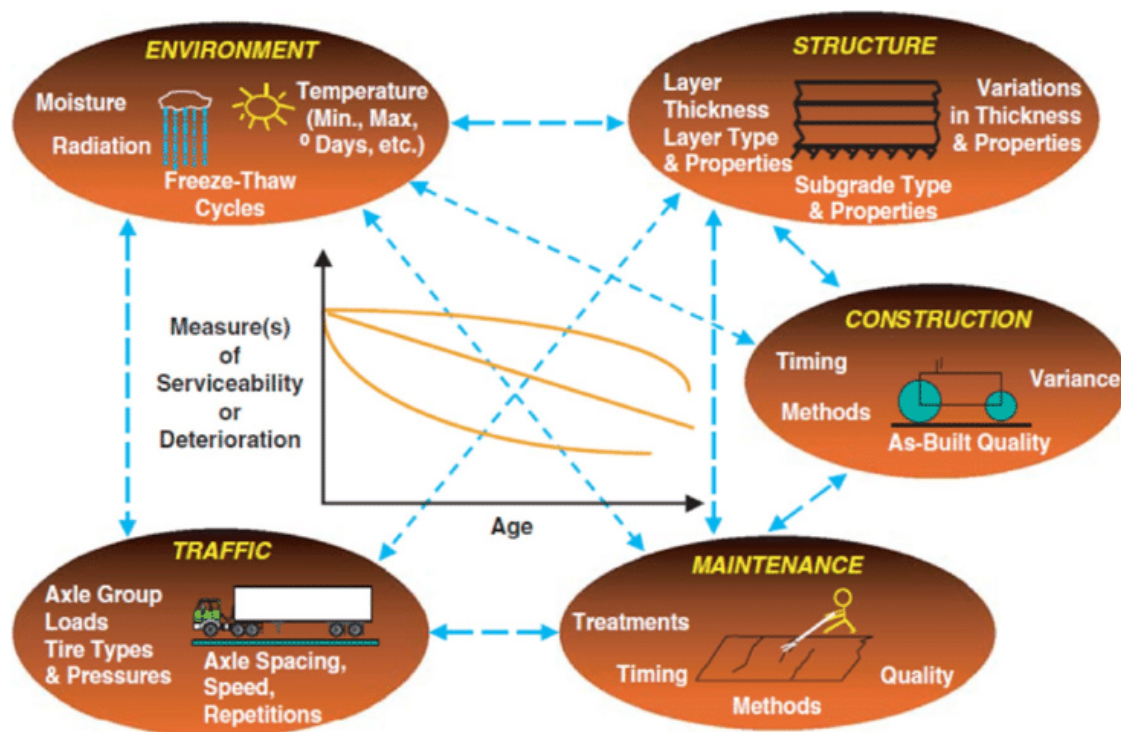

Figure III.2. A recapitulation of the parameters influencing the pavement design according to (Younos *et al*, 2020). Source: [10.1007/s41062-020-0275-3](https://doi.org/10.1007/s41062-020-0275-3)

III.3. Methods for designing pavement sub-layers

The design of pavement sub-layers is a critical aspect of pavement engineering, as these layers provide essential support, distribute loads, and contribute to the overall stability and longevity of the pavement structure. Proper design methods ensure that the sub-layers can withstand traffic loads, environmental influences, and long-term stress without excessive deformation or failure.

Various approaches are used to design pavement sub-layers, ranging from empirical methods based on historical performance data to mechanistic-empirical models that consider material behavior under actual loading conditions. Key factors influencing sub-layer design include soil properties, drainage conditions, traffic loads, and climate effects. Additionally, stabilization techniques, material selection, and layer thickness optimization play a vital role in enhancing pavement performance.

In this section, we will explore the primary methods used for designing pavement sub-layers, including traditional empirical approaches, analytical methods, and modern advancements that integrate geotechnical engineering principles and material innovations. Understanding these methods is essential for designing durable, cost-effective pavements that can perform efficiently under various conditions. Indeed, the evolution of pavement design methods according to (Zornberg, et al 2010) is depicted in Figure III.3

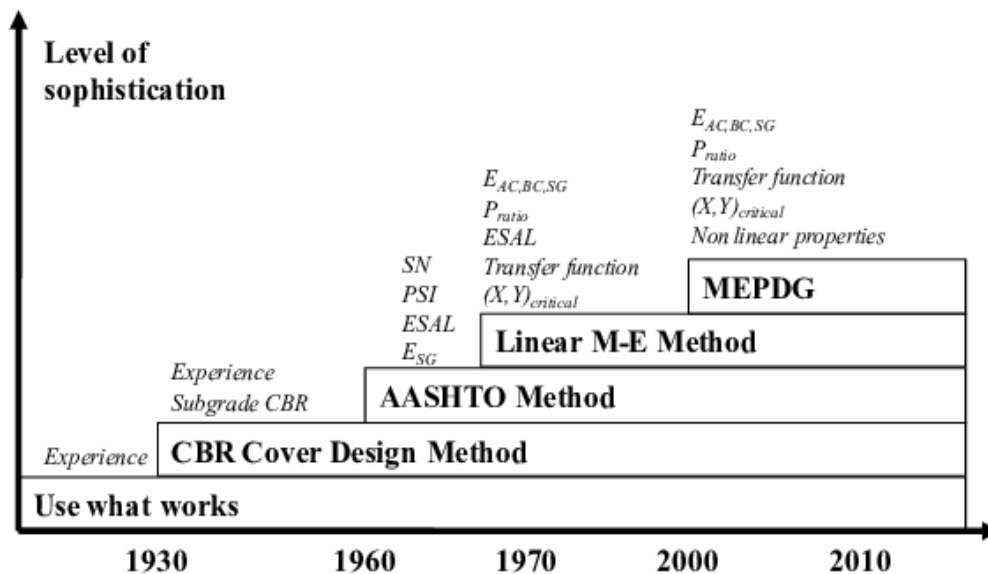

Figure III.3. Evolution of pavement design methods according to (Zornberg, et al 2010)

III.3.1. Empirical Methods

Empirical methods for pavement design are based on observations, historical data, and large-scale experiments rather than purely theoretical calculations. These methods establish relationships between pavement performance, traffic loads, material properties, and environmental conditions by analyzing past performance records and field test results.

One of the most well-known empirical approaches is the AASHTO road test method, which formed the basis for many modern pavement design guidelines. Empirical methods typically use design charts and empirical equations to determine pavement thickness and material selection based on expected traffic loads and subgrade conditions. These methods are relatively simple to apply and have been widely used in highway engineering for decades.

However, empirical methods have limitations, as they are heavily dependent on the specific conditions under which the original data were collected. They may not always account for modern materials, evolving traffic patterns, or climate variations. As a result, empirical methods are often supplemented with or replaced by analytical or numerical approaches, which combine empirical data with engineering principles for more adaptable and precise pavement design. In this section, we will explore the key empirical methods used in pavement design, their advantages and limitations, and their role in historical and modern engineering practices.

III.3.1.1. California bearing ratio (CBR) method

The California Bearing Ratio method is based on the CBR test. This test involves the penetration of a cylindrical sample of soil with a 15 cm diameter compacted to 90% of the modified Proctor optimum (OPM).

The chart showing the pavement thickness based on the CBR index value and the acted load (P) is represented in Figure III.4.

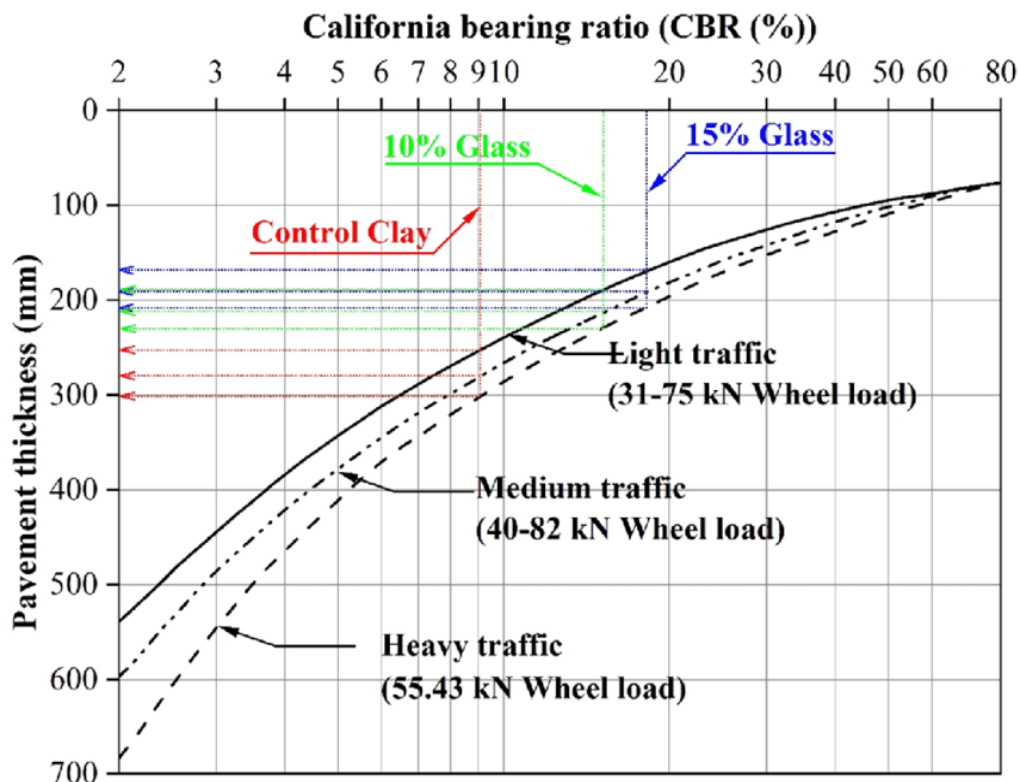

Figure III.4. Chart of the pavement thickness based on CBR ratio of the load.

The total thickness of the pavement structure to be implemented is evaluated as follows:

$$e = \frac{100+150\sqrt{P}}{5+I_{CBR}} \quad (III.1)$$

I_{CBR} : California Bearing Ratio (%)

P : Load per wheel, $P = 6.5$ t (13 t/axle)

e : Equivalent thickness

III.3.1.2. Traffic-adjusted method

This method is the improvement of the CBR one by considering indeed the traffic. The thickness of the layer supporting the applied load is given by the following relation:

$$e_{eq} = \frac{100+(75+50\log_{10}(N))\sqrt{P}}{5+I_{CBR}} \quad (III.2)$$

In which N : is the average daily traffic for the forecast year, which is evaluated using Eq. (III.3).

$$N = T_H P_L \quad (III.3)$$

$$T_H = \frac{T_0}{2} (1 + \tau)^m \quad (III.4)$$

- T_H : Traffic forecast for a 15-year lifespan.
- P : Percentage of heavy trucks
- T_0 : Current traffic (vehicles/day)
- m : Forecast year
- τ : Traffic growth rate (in %)
- P_L : Load per wheel ($P_L = 6.5$ t or 13 t axle)
- I_{CBR} : California Bearing Ratio of the supporting soil (in %)

The concept of equivalent thickness is introduced to account for the different mechanical qualities of layers. The equivalent thickness of a layer is equal to its actual thickness multiplied by a numerical coefficient (a) called the equivalence coefficient.

The equivalent thickness of the pavement is the sum of the equivalent thicknesses of the layers:

$$e_{eq} = \sum e_r \times a_i = a_1 e_1 + a_2 e_2 + a_3 e_3 \quad (III.5)$$

Where:

- e_1, e_2, e_3 : the actual thicknesses of the layers

In addition, Table III.1. provide the equivalence coefficients according to each used materials in pavement construction.

Table III.1. Equivalence coefficients of used materials in pavement construction

Used materials	Equivalence coefficient (a _i)
Bituminous concrete and dense coating	2.0
Bituminous gravel	1.6 to 1.7
Cement sand	1.0 to 1.2
Gravel and crushed gravel	1.0
Rolled gravel, sandy gravel, and alluvial gravel	0.75
Sand	0.5
Cement gravel - Slag gravel	1.5
Tuff	0.6

III.3.1.2. SETRA structural catalogue method

The SETRA structural catalogue method is approved by the Algerian regulations B60-B61. It simultaneously considers the class of heavy traffic over a 20-year operational period, as well as the class of the supporting soil. The traffic class is directly related to the number of heavy trucks with a payload greater than 50 KN per day on the most heavily loaded lane.

Table III.2 shows the traffic classes according to Algerian regulations B60-B61.

Table III.2. Traffic classes according to the Algerian regulations B60-B61

Traffic class	Cumulative traffic in heavy trucks over 20 years
T1	$T_c < 7.3 \times 10^5$
T2	$3.7 \times 10^5 < T_c < 2 \times 10^6$
T3	$2 \times 10^6 < T_c < 7.3 \times 10^6$
T4	$7.3 \times 10^6 < T_c < 4 \times 10^7$
T5	$T_c > 4 \times 10^7$

The cumulative traffic is given by the expression:

$$T_c = 365. T_{HV} \left(1 + \frac{(1+\tau)^n - 1}{\tau} \right) \quad \text{(III.6)}$$

Where:

- T_{HV} : Traffic in heavy trucks in the year of commissioning (vehicles/day)
- n : Service life ranging from 15 to 25 years depending on the level of the main network considered
- τ : Traffic growth rate (in %)

The supporting soil class is related to the CBR index value and the maximum density from the modified Proctor test. The different soil classes typically considered are summarized in the following Table III.3.

Table III.3. CBR indexes of the supporting soil according to B60-B61

Soil class	CBR index (%)
S1	25-40
S2	10-25
S3	5-10
S4	< 5

III.3.1.3. L.C.P.C method

The Central Laboratory for Bridges and Roads (LCPC i.e. French) method derived from the A.A.S.H.T.O tests, is based on determining the equivalent traffic, given by the following expression:

$$T_{eq} = 365 \cdot \frac{T_t \cdot a [(1+g)^n - 1]^{0.75P}}{(1+g)^{-1}} \quad (\text{III.7})$$

T_{eq} : Equivalent traffic per 13-ton axle.

T_t : Traffic at the time of road commissioning.

a : Coefficient depending on the number of lanes.

g : Annual growth rate.

n : Road service life.

P : Percentage of heavy trucks.

Once the value of the equivalent traffic is determined, the equivalent thickness (e) is then found based on T_{eq} , ICBR using the L.C.P.C. chart provided in Figure III.5. The L.C.P.C. chart is divided into a number of zones, for which recommendations are made based on the nature and quality of the base layer.

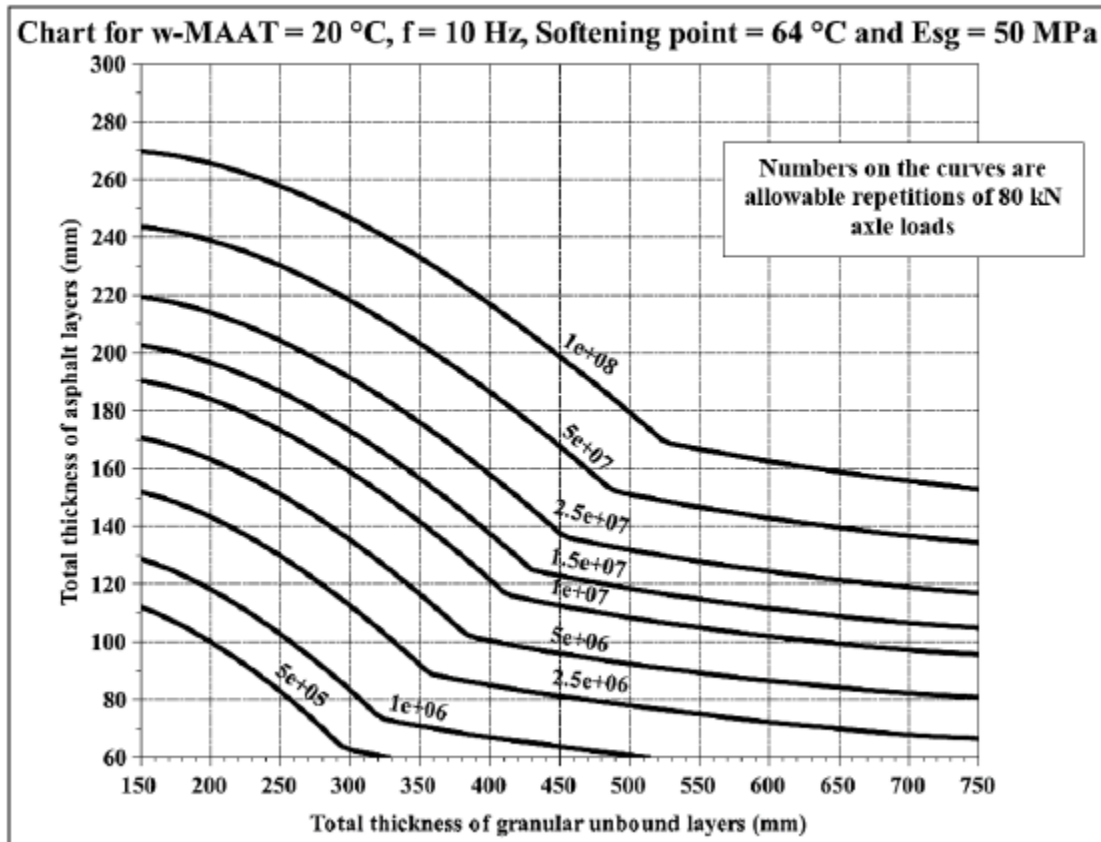

Figure III.5. Chart of the pavement thickness based on LCPC method.

III.3.1.4. The pavement design catalogue method

The pavement design catalogue method is based on theoretical and empirical approaches. The use of the design catalogue involves the same parameters used in other pavement design methods: traffic, materials, supporting soil, and environment. To enhance soil bearing capacity, shape layers are used.

The new pavement design catalogue method has researched the variation in CBR with different thicknesses of shape layers, their placement mode (number of layers), and the nature of the material used (the most common in Algeria) for constructing shape layers (Table III.4).

Table III.4. Different thicknesses of the shape layer according to the catalogue method.

Soil bearing capacity	Base-layer material	Base-layer thickness	Bearing capacity
< S4	Untreated	50 cm (2 layers)	S3
S4	Untreated	35 cm	S3
S4	Untreated	60 cm (2 layers)	S2
S3	Untreated	40 cm (2 layers)	S2
S3	Untreated	70 cm (2 layers)	S1

III.3.1.5. AASHTO Method

The AASHTO road test method is one of the most significant empirical approaches to pavement design, developed from large-scale road tests conducted in the late 1950s (AASHTO, 1993). This method laid the foundation for modern pavement design practices by establishing relationships between traffic loads, pavement performance, and material properties.

The AASHTO method is based on empirical equations derived from field test data, linking pavement thickness to the expected number of axle loads and the acceptable level of serviceability loss over time. The key design parameters include:

- Present serviceability index: A measure of pavement condition and ride quality.
- Equivalent single axle load: A standardization of traffic loads into 80 KN single axle loads.
- Soil support value: Represents the bearing capacity of the subgrade.
- Regional factors: Adjustments for local climate, material properties, and construction quality.

This method enables the establishment of equivalence laws between axles of different loads, statistically correlates deflections with pavement structure, defines a service quality index for pavements (Present Serviceability Index), and an index of thickness, which can be expressed as a linear function of the thicknesses of different layers. The proposed chart of the (AASHTO,1993) method is given the Figure III.6.

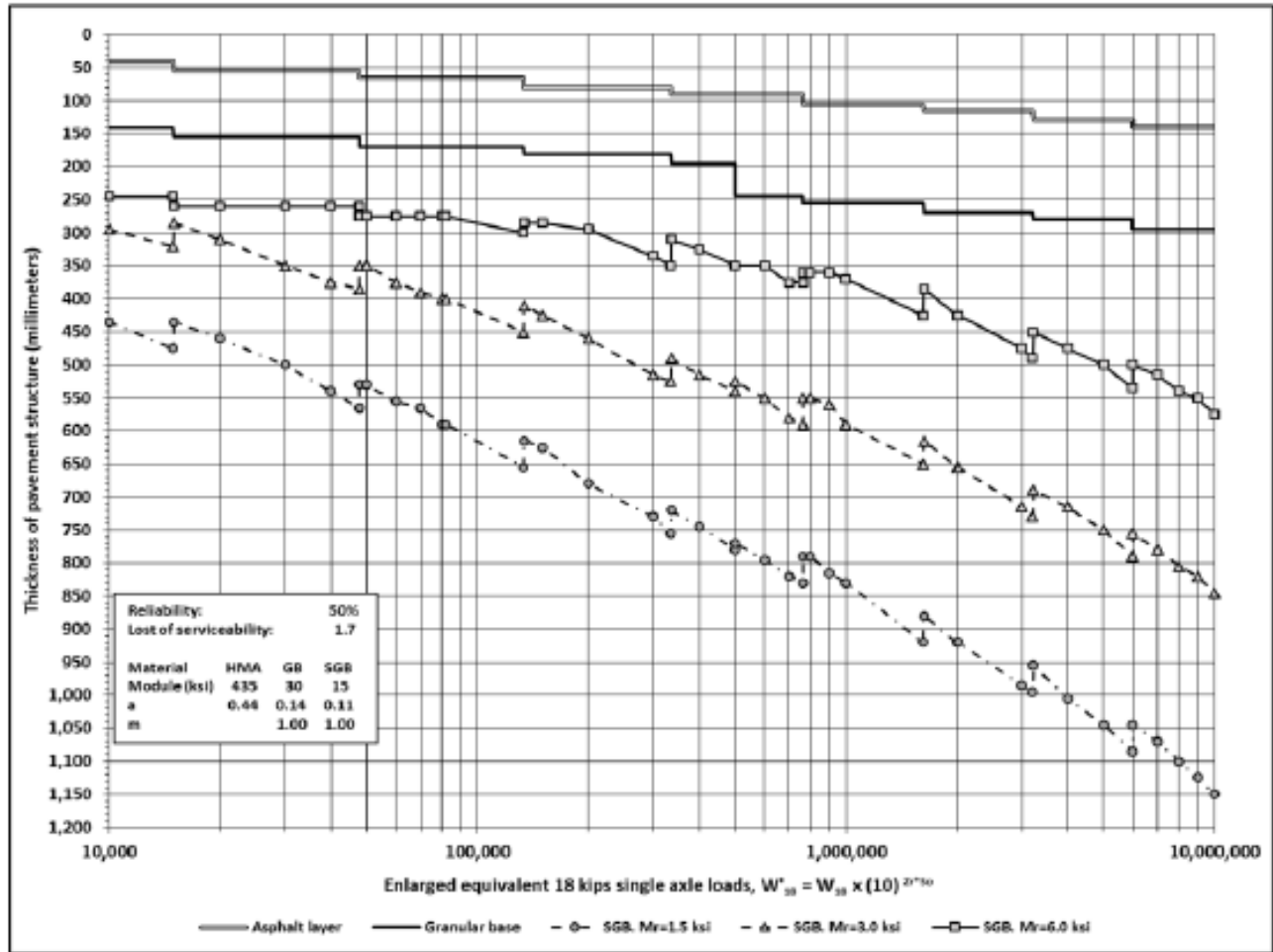

Figure III.6. Flexible pavement design chart based on the (AASHTO,1993) method

III.3.1.6. Asphalt institute method

The associated method determines the thickness of a pavement in either a single layer or multiple layers. Transitioning from a single layer to multiple layers is done using substitution ratios that propose combinations of asphalt concrete, granular base, and granular sub-base layers, respecting a ratio influenced by the material's nature on each layer's thickness.

The substitution ratios recommended by the Asphalt institute are based on extensive research using various types of materials. For flexible pavements, this method determines the total thickness of the asphalt pavement and the thickness of each layer using a chart provided in Figure III.7 under the same soil conditions and for identical traffic conditions. The base data include:

- The intensity and nature of traffic expressed as equivalent traffic during the design period
- The soil bearing capacity obtained from CBR tests and plate loading tests. Alternative solutions are determined using appropriate substitution factors and respecting the minimum required thicknesses for the asphalt surface and granular base layer. The figure below helps determine the thicknesses of the different pavement layers.

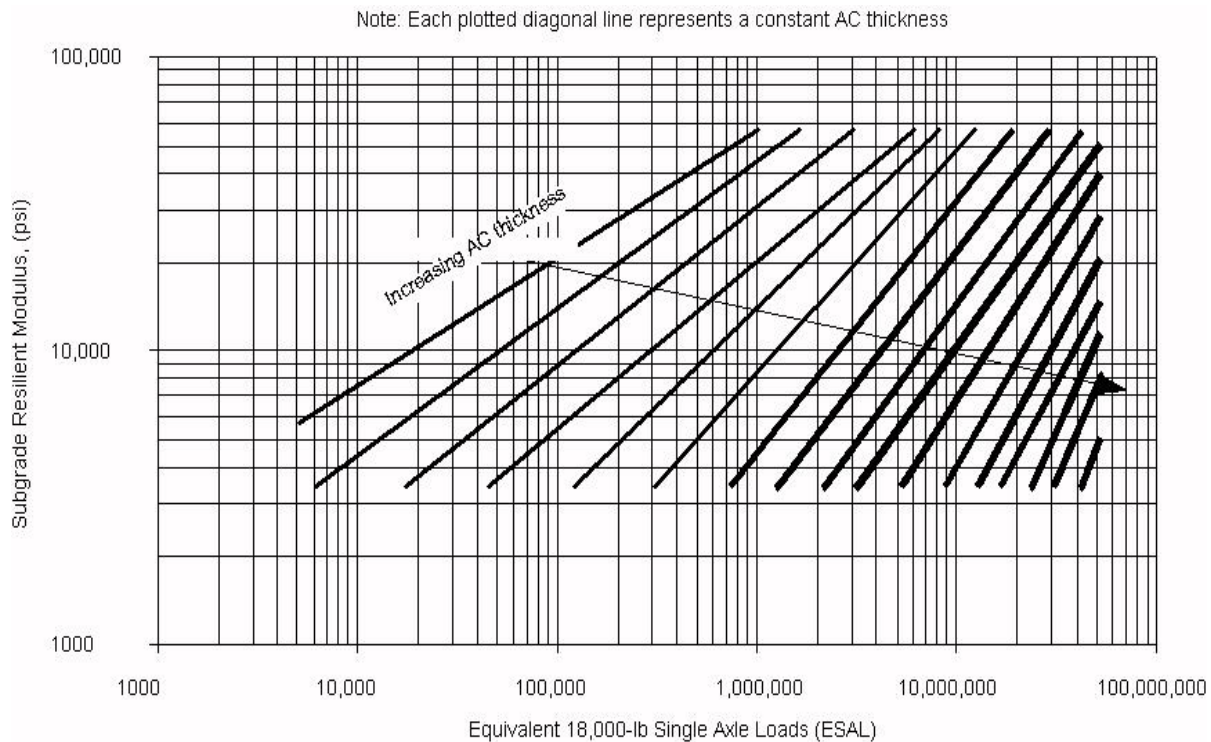

Figure III.7. Sketch of asphalt institute design chart for full-depth. *Source:* (redrawn from Asphalt institute, 1983)

III.3.2. Analytical and theoretical methods

These methods are referred to as analytical because they partially rely on an analytical approach, complemented by empirical data. They are based on the mechanics of continuous media and the resistance of materials and depend on analyzing the results of laboratory or experimental site tests combined with field data to validate the selected structures.

The process is carried out in two stages:

- Calculation of permissible stresses and deformations in the pavement based on expected traffic (fatigue and deformation model).
- Calculation of the required thicknesses to meet the criteria for permissible stresses or deformations.

Theoretical methods in pavement design are based on fundamental theories and principles derived from civil engineering and materials science. These methods provide a theoretical foundation for understanding pavement behavior and guiding design decisions. Key aspects include:

- **Theory of elasticity:** This theory helps understand how pavements deform under loading. It provides formulas for calculating stress and strain in elastic materials, which are foundational for analyzing pavement performance.

- **Mechanics of materials:** This theoretical approach focuses on understanding the behavior of materials under various forces and conditions. It includes the study of material properties such as modulus of elasticity, Poisson's ratio, and shear strength, which are essential for designing durable pavements.
- **Thermal and moisture effects:** Theoretical methods also consider how temperature and moisture affect pavement materials. This includes studying how temperature fluctuations lead to expansion and contraction, which can cause cracking and other forms of distress.
- **Mathematical modeling:** Theoretical methods use mathematical models to describe and predict the behavior of pavement structures. These models are based on the principles of continuum mechanics and are used to derive equations that represent pavement performance under different conditions.

III.3.3. Numerical Methods

The development of numerical methods, particularly the finite element method, allows for the use of more realistic models. This enables accounting for material non-linearity and complex contact conditions between different layers.

Finite element modeling of pavement structures has been explored since 1967. Cesar-LCPC is used whenever continuous, elastic, and linear multilayer models prove too simplistic. This approach specifically handles:

- The three-dimensional nature of the structure due to non-infinite geometries in plan.
- Non-linearity or evolution of contact conditions.
- Viscoelastic behavior of materials under rolling loads.

Numerical methods play a crucial role in modern pavement design by enabling engineers to analyze complex pavement systems with high accuracy. These methods use computational techniques to solve mathematical models and simulate pavement behavior under various conditions. Here are the key numerical methods commonly used in pavement design:

III.3.3.1. Finite element method (FEM)

The finite element method (FEM) is a powerful numerical technique used to analyze complex structural problems by dividing the pavement structure into smaller, manageable elements. Each element is solved for its behavior, and the results are combined to obtain the overall response of the pavement system. Some applications in pavement design are emphasized as follow:

- **Stress and strain analysis:** FEM is used to calculate stress and strain distributions within different layers of a pavement structure under various loading conditions.

- **Thermal effects:** FEM can model temperature variations and their impact on pavement materials.
- **Deflection analysis:** It helps in predicting how pavements will deflect under traffic loads, which is crucial for evaluating structural performance.

III.3.3.2. Finite difference method (FDM)

The finite difference method (FDM) approximates differential equations by discretizing the problem domain into a grid and solving the equations at discrete points. It is particularly useful for problems involving time-dependent or dynamic conditions. Some applications in pavement design are emphasized as follow:

- **Dynamic loading:** Used to analyze pavement response under time-varying loads or environmental conditions.
- **Thermal analysis:** Can model heat transfer and temperature effects within the pavement layers.

III.3.3.3. Discrete element method (DEM)

The discrete element method (DEM) models the behavior of granular materials by representing them as a collection of distinct, interacting particles. This method is particularly suited for analyzing materials like soil and aggregate that exhibit discrete particle behavior. Some applications in pavement design are emphasized as follow:

- **Granular materials:** Used to study the behavior of base and sub-base materials in pavement structures.
- **Aggregate interactions:** Helps in understanding how different types of aggregates interact and affect pavement performance.

III.3.3.4. Multilayer elastic analysis

Multilayer elastic analysis is a numerical method used to analyze pavements composed of multiple layers, assuming each layer behaves elastically. It calculates stress, strain, and deflection by considering the interaction between different layers. Some applications in pavement design are emphasized as follow:

- **Layered pavements:** Used to analyze the performance of flexible and rigid pavements with multiple layers.
- **Structural evaluation:** Helps in assessing the structural capacity and serviceability of the pavement system.

Based on the previous discussion, it is evident that each method has its advantages and disadvantages, summarized in the following Table III.5.

Table III.5. Recapitulation of advantages/disadvantages of pavement design methods

Method	Advantages	Disadvantages
Empirical Methods	<ul style="list-style-type: none"> - Simple to use with design charts and equations. - Based on real-test performance data. - Well-established and widely used in practice. - Requires minimal computational effort. 	<ul style="list-style-type: none"> - Limited applicability to conditions different from the original data. - Does not accurately consider modern materials and traffic loads. - Less adaptable to new environmental conditions and innovations.
Theoretical Methods	<ul style="list-style-type: none"> - Based on fundamental engineering principles (stress-strain relationships, elasticity theory). - Provides a more scientific and general approach to pavement behavior. - Can be applied to a wider range of materials and conditions. 	<ul style="list-style-type: none"> - Requires many assumptions, which may not always match real-world conditions. - More complex and requires a deeper understanding of material behavior. - Limited by the accuracy of input parameters.
Numerical Methods	<ul style="list-style-type: none"> - Highly precise and adaptable to various conditions. - Can model complex interactions between loads, materials, and environmental factors. - Useful for optimizing pavement design and predicting long-term performance. 	<ul style="list-style-type: none"> - Computationally intensive, requiring specialized software and expertise. - More expensive and time-consuming than empirical methods. - Requires accurate input data for reliable results.

III.4. Conclusion

Pavement design is a multidisciplinary process influenced by various factors, including traffic loads, climate, soil conditions, material properties, construction quality, and maintenance strategies. Each of these parameters plays a crucial role in determining pavement performance, durability, and long-term sustainability. Methods for designing pavement sub-layers, such as empirical, theoretical, and numerical approaches, provide engineers with tools to optimize pavement structures based on site-specific conditions. Empirical methods, such as the AASHTO road test, rely on historical data and simplified equations, making them

practical but limited in adaptability. Theoretical methods use fundamental engineering principles to analyze stresses and strains within pavement layers, while numerical methods offer advanced computational models for simulating complex pavement behavior.

Selecting the appropriate pavement design method requires balancing accuracy, computational effort, and real-world applicability. Empirical approaches are widely used for their simplicity, whereas theoretical and numerical models provide deeper insights into pavement mechanics and long-term performance. Additionally, considering external factors such as climate, environmental impacts, and material advancements is essential for ensuring pavement resilience. A well-designed pavement accounts for all these aspects, leading to cost-effective solutions that minimize maintenance needs and extend service life. By integrating traditional empirical knowledge with modern analytical techniques, engineers can develop more efficient, sustainable, and durable pavement systems.

Therefore, the subsequent chapter examines the geometric characteristics and features of pavement and roadways in order to correspond to the most cost-effective solution and meet certain minimum conditions defined by the natural environment, particularly the topography, geology and the anticipated future traffic.

Chapter IV: Geometric Features of Traffic Lane Roads

IV.1. Introduction

The geometric features of traffic lane roads are crucial in ensuring safe, efficient, and economical transportation. These features define how a road is designed and constructed, influencing the driving experience, vehicle performance, and overall traffic flow. Understanding these geometric elements is essential for engineers and planners to create roadways that meet the needs of both current and future traffic. When developing any road project, the engineer must start by determining the road's location in nature and adapting it as rationally as possible to the terrain's configuration.

Geometric roadway design can be classified into three main parts: alignment, profile, and cross-section. Combined, they provide a three-dimensional layout for a roadway.

- The plan profile is defined as a series of horizontal tangents and curves.
- The longitudinal profile is the vertical aspect of the road, including crest and sag curves, and the straight grade lines connecting them.
- The cross-section profile shows the position and number of vehicle and bicycle lanes and sidewalks, along with their cross slope or banking. Cross sections also show drainage features, pavement structure and other items outside the category of geometric design.

The geometric characteristics of these elements must correspond to the most cost-effective solution and meet certain minimum conditions provided by nature, particularly topography and geology; as well as the anticipated future traffic.

IV.2. Plan profile

The plan profile is a precise, scaled representation of a road's layout as projected onto a horizontal plane. It serves as the foundation for road design, ensuring smooth vehicle movement and safety. Typically, the alignment comprises a combination of straight sections (tangents) and circular curves, which define the road's horizontal path.

A real illustration of a road alignment involves visualizing various elements of road design in a detailed and practical manner. In Figure IV.3 a description of a typical road alignment, including its key components and their measurements.

The geometric characteristics of the plan alignment must ensure conditions of comfort and stability, as specified in road codes according to the design speed and the friction provided by the road surface layer.



Figure IV.3. Real illustration of a road alignment. *Source:* https://en.wikipedia.org/wiki/Geometric_design_of_roads

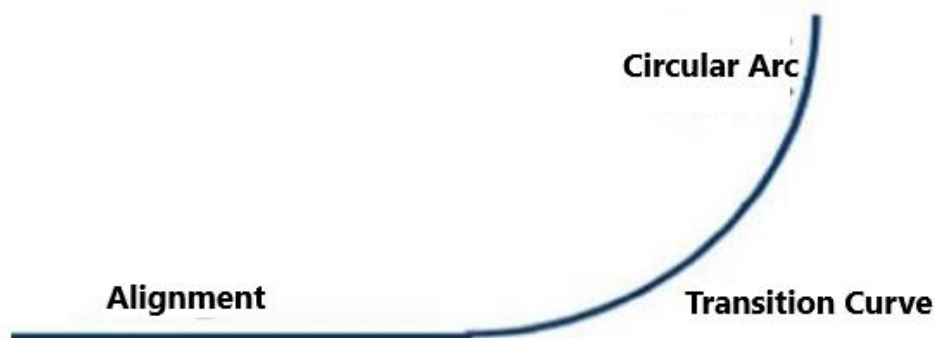

Figure IV.4 Components of a plan profile. *Source:* Meziani F (2023)

In order to ensure safety of road users, the average speed or velocity in the alignments is related to the friction coefficients (f_t) and (f_l) which are critical parameters used in road design to ensure safety and comfort for vehicles navigating curves.

They relate to the friction between the vehicle tires and the road surface, affecting how vehicles handle turns and gradients.

- **Longitudinal friction coefficient (f_l):** This coefficient measures the friction along the direction of vehicle travel. It is crucial for acceleration, braking, and maintaining vehicle control. As speed decreases, the coefficient generally increases. This means that at lower speeds, the road surface provides more friction, which is important for braking and acceleration.
- **Transversal friction coefficient (f_t):** This coefficient measures the friction perpendicular to the direction of vehicle travel, which is important for handling curves and maintaining stability during turns. This coefficient tends to be lower compared to the longitudinal friction coefficient. It increases with decreasing speed, reflecting the greater need for traction when navigating curves at lower speeds.

The following Table IV.1 provides typical values for the longitudinal and transversal friction coefficients based on different speed categories. These values are used to design road geometries that accommodate various driving conditions.

Table IV.1. Values of friction coefficients f_l and f_t according to (B40, 1973)

Category	Speed in Km/h	Longitudinal coefficient f_l	Transversal coefficient f_t
1-2	120	0.33	0.10
	100	0.36	0.11
	80	0.39	0.13
	60	0.42	0.16
	40	0.45	0.20
3-4-5	120	0.36	0.11
	100	0.40	0.125
	80	0.43	0.15
	60	0.46	0.18
	40	0.49	0.22

The reference speed or velocity (V_R) is a fundamental parameter in road design, used to establish the minimum geometric requirements necessary to ensure both user comfort and safety. It dictates critical elements such as curve radii, sight distances, and lane widths. To maintain a consistent driving experience, the reference speed should remain relatively uniform across different road sections, with variations occurring only at significant transitions, such as entering an urban area or encountering a major change in terrain. Sudden fluctuations in reference speed can disrupt traffic flow and reduce safety.

Table IV.2 provides a summary of the base speeds adopted in various countries, reflecting regional standards and design practices.

Table IV.2 Range of Base Speeds Used in Some Countries. *Source: Meziani F (2023)*

Country	Road type	V_R values (Km/h)
Switzerland	High-capacity roads	80 - 120
	Main roads, Collector roads	60 - 120
	Major roads, easy terrain	50 - 80
France	Motorways	140
	Motorways, very rugged topography	100
	Major roads, very easy topography	120
	Ordinary roads, less rugged topography	100
	Ordinary roads, rugged topography	80
	Ordinary roads, hilly topography	65
Italy	High-capacity roads	150
	Main roads, Collector roads	100
	Major roads, easy terrain	120
USA (AASHO)	Flat roads	115
	Rugged topography	95
	Mountain roads	95
Algeria	Urban roads	40 - 50
	Rural roads	80 - 100
	Motorways	100 - 120

The choice of reference speed on roadways depends on several key factors. These factors collectively help in determining safe and effective reference speeds for different types of roadways.

- **Traffic conditions:** Traffic flow, congestion levels, and typical vehicle speeds influence the choice of reference speed. For example, higher reference speeds might be set on highways with lighter traffic, while lower speeds are often necessary in congested urban areas.

- **Road design and geometry:** The design of the roadway, including curves, gradients, and road surface quality, affects reference speeds. Curves and steep grades often require lower reference speeds to ensure safety.
- **Safety considerations:** Reference speeds are set with safety in mind, taking into account factors such as visibility, pedestrian crossings, and proximity to intersections. Safety studies and accident data help determine appropriate speeds.
- **Regulatory guidelines:** Local, state, and national regulations and guidelines provide frameworks for setting reference speeds. These regulations are often based on extensive research and historical data.
- **Land use and development:** The nature of the surrounding area, such as residential, commercial, or industrial zones, can influence speed limits. Residential areas, for example, often have lower speed limits to protect pedestrians and cyclists.
- **Weather conditions:** Weather patterns and seasonal changes can affect speed limits. For example, in areas prone to ice or heavy rain, lower speeds might be recommended or enforced.
- **Traffic control devices:** Signage, signals, and road markings play a role in determining and communicating appropriate reference speeds. These devices must be visible and provide clear guidance to drivers.
- **Historical data and studies:** Historical accident data and traffic studies can inform the choice of reference speeds, helping to balance safety with efficiency.
- **Driver behavior and compliance:** Observations of driver behavior and compliance rates can influence speed limit adjustments. If drivers consistently exceed posted limits, adjustments might be made to improve adherence and safety.
- **Public input and feedback:** Community input and feedback can also play a role in setting reference speeds, especially in areas where there are concerns about safety or quality of life.

IV.2.1. Rules in plan profile designing

To achieve a well-designed plan alignment that meets engineering standards, several key considerations must be taken into account. First, the alignment should avoid passing through sensitive areas such as agricultural lands, forested regions, and private properties, as these can lead to legal complications, environmental disruption, and increased costs. Additionally, it is essential to steer clear of geologically unstable areas to prevent potential issues such as landslides, soil erosion, or foundation failures, which could compromise the road's long-term stability. Another crucial factor is minimizing crossings over rivers and watercourses, as constructing bridges or other major engineering structures can be costly and technically challenging.

Furthermore, the alignment should be designed to integrate harmoniously with the natural terrain to minimize excessive earthworks, reducing both environmental impact and construction costs. Where possible, large curve radii should be used to enhance safety and driving comfort, especially in open terrain. The design must also respect the maximum allowable gradient and align closely with the existing contour lines to ensure a smooth transition between different elevation levels. Additionally, adhering to the minimum required length of straight alignments where feasible contributes to driving stability and visibility. Finally, the road should seamlessly connect with existing transportation networks, facilitating accessibility and continuity within the broader infrastructure system.

IV.2.2. Elements of plan profiles

Elements of a plan profile refer to the key geometric components that define the horizontal layout of the road, ensuring safe and efficient movement. These elements include straight sections (tangents) for uninterrupted travel, horizontal curves for smooth directional changes, transition curves to provide gradual shifts between straight and curved paths, and intersections or crossings where roads meet. Proper alignment design enhances safety, comfort, and operational efficiency while minimizing environmental and construction challenges.

IV.2.2.1. Alignments

In roadway design, ensuring proper alignment lengths between consecutive curves is essential for maintaining driving comfort, safety, and consistency in vehicle trajectory. To achieve this, a minimum alignment length (L_{min}) must be maintained between two successive circular curves in the same direction. This minimum length is determined based on the distance a vehicle travels in five seconds at the maximum permitted speed corresponding to the larger radius of the two curves, according to (AASHTO, 2012). This criterion allows for a smoother transition between curves, reducing abrupt directional changes and ensuring adequate reaction time for drivers.

Similarly, the maximum alignment length (L_{max}) is established to prevent excessively long straight sections that may lead to monotony and reduced driver attention. It is defined as the distance a vehicle covers in 60 seconds at the same maximum permitted speed, according to (AASHTO, 2012). This upper limit helps maintain the dynamic nature of the roadway while promoting optimal visibility, vehicle control, and overall driving efficiency. By adhering to these alignment constraints, road designers can enhance safety, optimize traffic flow, and improve the overall driving experience. The minimum and maximum alignment length provided by (AASHTO, 2012) according to the reference speed (V_R) are given in the following equations.

$$L_{min} = T \times V_R / 3.6 \quad (T = 5 \text{ sec}) \quad (\text{IV.1})$$

$$L_{max} = T \times V_R / 3.6 \quad (T = 60 \text{ sec}) \quad (\text{IV.2})$$

IV.2.2.2. Circular Arcs

A circular arc is a key element in horizontal road plan profile, providing a smooth transition between straight sections with a constant radius to ensure stability and comfort. Its design is influenced by several factors, including design speed, which determines the required curve radius, superelevation to counteract centrifugal force referred to as: cant, tire-road friction for vehicle grip, sight distance to maintain clear visibility, and terrain constraints that impact feasible alignment. Properly designed circular arcs enhance safety, minimize lateral forces, and ensure efficient vehicle movement.

In a curve with radius (R), the vehicle experiences centrifugal force that can lead to instability (i.e. Figure IV.5 and IV.6). To counteract this force, the road is banked transversely towards the inside of the curve, a slope known as superelevation or cant, which is expressed by its tangent. This helps to prevent skidding and improve vehicle stability.

In road geometry, cant (also called superelevation) refers to the tilting of the roadway surface in a curve to help vehicles maintain stability and reduce lateral force. It is the transverse slope provided on a curve to counteract the centrifugal force acting on vehicles as they navigate the turn.

The superelevation or Cant (C) should not be too large (risk of skidding at low speeds during rainy or icy conditions), and should not be too small to ensure proper water drainage.

The maximum cant corresponds to the absolute minimum radius R_{Hm} with:

- $C_{max}=7\%$ for categories (1-2);
- $C_{max}=8\%$ for categories (3-4);
- $C_{max}=9\%$ for category 5.

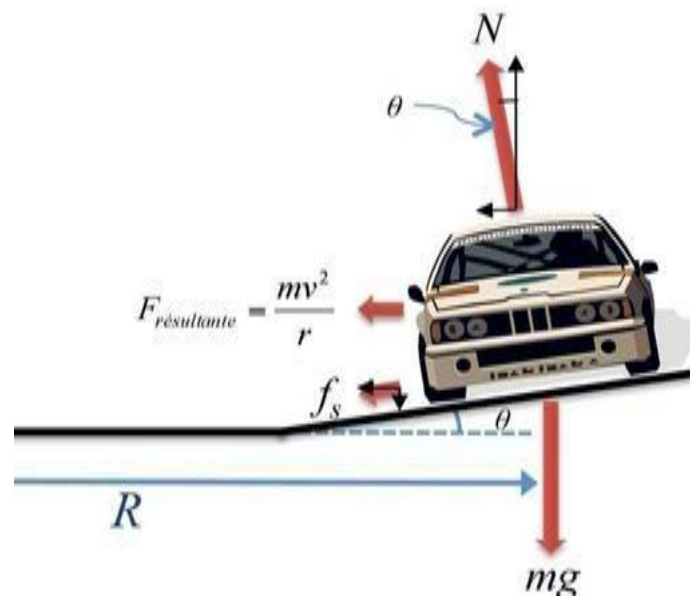

Figure IV.5. Acted loads and stability of a vehicle. *Source: Meziani F (2023)*

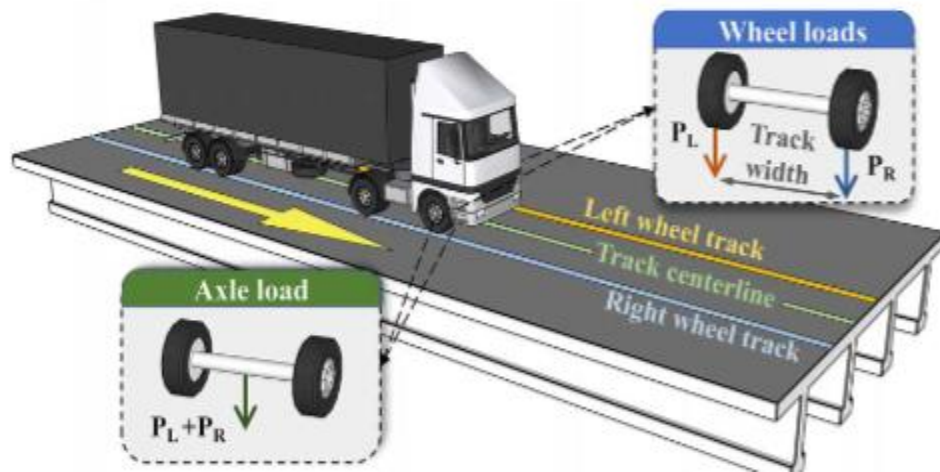

Figure IV.6. Acted loads and stability of a heavy truck. *Source :*
<https://ascelibrary.org/doi/10.1061/JBENF2.BEENG-5604>

Absolute minimum horizontal radius (R_{hm}): This is the minimum radius for which vehicle stability is assured. It should never be less than this value. It is defined as the maximum superelevation radius.

$$R_{hm} = \frac{V_R^2}{127 + (f_t + C_{max})} \quad (IV.3)$$

For example; a category 1 or 2 road with $V_R=80$ km/h and $f_t=0.13$, Absolute Minimum Horizontal Radius (R_{hm}) is assessed to be 251.96 m

Normal minimum radius (R_{hn}): The normal minimum radius R_{hn} should allow vehicles traveling at speeds exceeding V_R by 20 km/h to travel safely.

$$R_{hn} = \frac{(V_R + 20)^2}{127 + (f_t + C_{max})} \quad (IV.4)$$

Minimum radius with superelevation (R_{hd}): This is the radius with minimal superelevation, beyond which roadways are banked towards the inside of the curve, ensuring that the residual centrifugal acceleration at speed V_b is equivalent to that experienced by a vehicle traveling at the same speed on a straight alignment. With $C_{min}=2.5\%$ for category 1–2 and 3% for categories 3–4–5

$$R_{hd} = \frac{V_R}{127 \times 2 \times C_{min}} \quad (IV.5)$$

Minimum non-superelevated radius (R_{nd}) If the radius is very large, the road retains its crown profile, and the superelevation becomes negative for one direction of travel. The minimum radius allowing this configuration is the minimum non-superelevated radius R_{nd} .

$$R_{nd} = \frac{V_b^2}{127 \times 0.035} \quad \text{For category 1-2} \quad (\text{IV.6})$$

$$R_{nd} = \frac{V_b^2}{127 + (f_0 - 0.035)} \quad \text{For categories 3-4-5} \quad (\text{IV.7})$$

In which f_0 is estimated to 0.007 for a road category 3 and 0.0075 for road category 4-5. For safety and comfort, the geometric design of roads must ensure satisfactory visibility conditions at both specific points and along straight sections. One of the tasks of road designers is to balance visibility needs with project-specific constraints. These requirements depend on the operating speed, reaction time, and maneuvering distance.

A curve may be obscured on the lower side by a cut slope, a building, or forest. To ensure adequate visibility for drivers, it may be necessary to move the slope back or remove obstacles over a certain width. Alternatively, increasing the curve radius until visibility is assured is another solution.

IV.2.2.3. Progressive transitions (Clothoïde)

A clothoïde, also known as a spiral curve or transition curve, is a curve used in roadway and railway design to provide a gradual transition between a straight path and a circular arc. The purpose of a clothoïde is to ensure a smooth change in curvature, which enhances vehicle comfort and safety. Here's an overview of its significance and application:

- **Smooth transition:** The clothoïde gradually increases the curvature from zero (straight path) to a constant rate of curvature (circular arc). This transition reduces abrupt changes in lateral acceleration, which improves the driving experience.
- **Vehicle comfort:** It helps to reduce lateral forces on the vehicle and its occupants, making the curve easier to navigate and minimizing discomfort.
- **Safety:** By easing into the curve, the clothoïde reduces the risk of skidding or loss of control, particularly at higher speeds or in adverse weather conditions.
- **Design flexibility:** It allows for smoother transitions between different geometric elements of the road or rail network, improving overall design flexibility.

In a clothoïde, the curvature (κ) increases linearly with the length of the curve (s). This means that the curvature at any point on the clothoïde is directly proportional to the distance along the curve from the start of the transition. The curvature $k(s)$ at any point is given by Eq. IV.8.

$$k(s) = \frac{s}{L^2} \quad (\text{IV.8})$$

where (s) is the distance along the curve from the beginning of the clothoïde, and L is a parameter related to the length of the clothoïde. The length of the clothoïde is typically

determined based on the desired rate of change in curvature and the design speed of the road or rail. It is designed to ensure that the transition is gradual and comfortable.

By incorporating clothoids into road and rail design, engineers can create smoother, safer, and more comfortable transitions between different geometric elements, enhancing the overall quality of the transportation infrastructure, as shown in Figure IV.7 and IV.8.

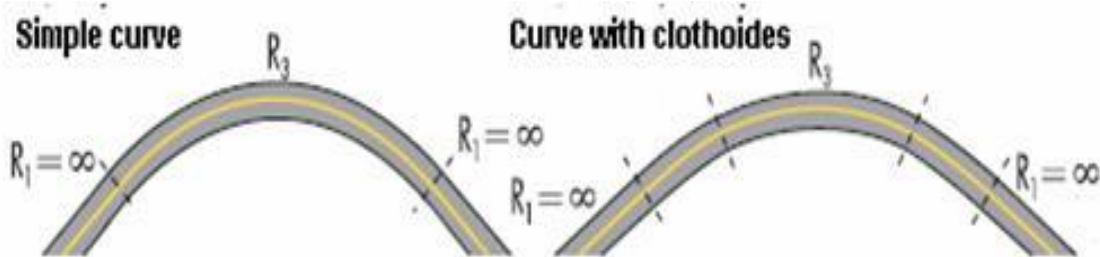

Figure IV.7. Sequence of horizontal alignment components. *Source:* (PIARC 2003) https://www.dacotaproject.eu/Links/erso/knowledge/Content/15_road/getting_initial_safety_design_principles_right.html

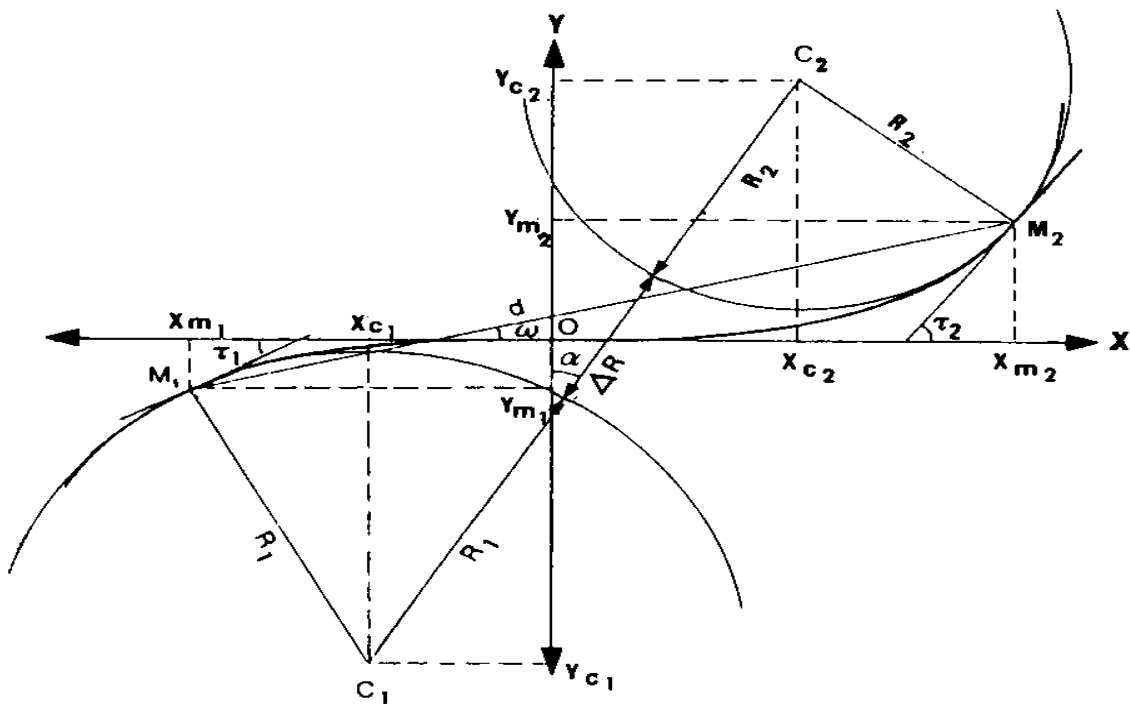

Figure IV.8. Example of clothoid assement according to (AFT) Association francophone de topographie. *Source:* <https://www.aftopo.org/categories-lexique/9-5-implantation-darc-de-clothoide/>

IV.3. Longitudinal profile

The longitudinal profile is a fundamental component of road design, representing a vertical cross-section along the centerline of the roadway. Unlike the horizontal projection seen in

the plan alignment, the longitudinal profile provides insight into the elevation changes of the road, ensuring a smooth and safe transition between different gradients. It is typically depicted at an appropriate vertical and horizontal scale to accurately reflect variations in terrain and road elevation.

This profile is composed of a series of straight segments, commonly referred to as ramps and slopes, which define the road's incline and descent. These sections are seamlessly connected by vertical curves, designed to provide a gradual transition between different slopes, enhancing both driving comfort and vehicle stability. Properly designed vertical curves ensure adequate sight distance, preventing sudden elevation changes that could compromise safety.

The longitudinal profile plays a crucial role in determining drainage efficiency, fuel consumption, and the overall functionality of the roadway. Excessive gradients can lead to increased energy consumption for vehicles, particularly for heavy trucks, while inadequate slopes may result in poor water runoff, leading to potential hydroplaning or pavement deterioration. Therefore, optimizing the longitudinal profile is essential for ensuring a safe, efficient, and cost-effective road infrastructure.

IV.3.1. Rules for drawing the longitudinal profile

The longitudinal profile of a road must adhere to established geometric regulations to ensure optimal comfort, visibility, safety, and efficient drainage. One of the key aspects of designing a proper longitudinal profile is minimizing earthworks by striking a balance between excavation and fill volumes. Excessive excavation can lead to high construction costs and environmental disturbances, while excessive fill can cause instability and require costly retaining structures. A well-balanced approach reduces material waste, lowers costs, and ensures a stable and sustainable roadway.

Another crucial factor in the longitudinal profile design is controlling gradients and elevation changes. The maximum allowable slope must not exceed regulatory limits, as steep inclines can make driving more difficult, especially for heavy vehicles, increasing fuel consumption and reducing safety. Prolonged steep gradients should be avoided to prevent excessive strain on vehicles and potential hazards in adverse weather conditions. Additionally, extreme fill heights should be minimized to maintain road stability and prevent structural issues. Proper planning is also essential to ensure smooth integration with existing road networks, allowing for safe and seamless connections.

To enhance driving comfort and safety, parabolic vertical curves should be incorporated to provide smooth transitions between different gradients. These curves help eliminate sudden changes in slope, improving both ride quality and stopping sight distance for drivers. Moreover, the longitudinal profile must be carefully coordinated with the plan alignment to create a harmonious and functional roadway. Proper integration of both horizontal and vertical geometry improves traffic flow, enhances safety, and facilitates drainage, preventing water accumulation that could damage the pavement or cause hydroplaning risks.

IV.3.2. Geometric elements of the longitudinal profile

The longitudinal profile of a road consists of a sequence of straight segments, including ascending ramps and descending slopes, which are smoothly connected by circular curves. At each point along this profile, key parameters must be determined, such as the altitude of the natural terrain, the altitude of the designed roadway, and the gradient of the project. The gradient, defined as the tangent of the angle between the longitudinal profile and the horizontal plane, is referred to as a "slope" in downhill sections and a "ramp" in uphill sections. These elements play a crucial role in ensuring the functionality, safety, and durability of the roadway.

To optimize road performance, both minimum and maximum gradients must be carefully considered. A completely flat roadway, known as a "plateau," should be avoided whenever possible, as it can lead to water accumulation and inadequate drainage. While transverse slopes assist in water runoff, longitudinal drainage through ditches or pipes is necessary, requiring a minimum gradient of 0.5%, with 1% being preferable. On the other hand, the maximum gradient is constrained by factors such as tire-road adhesion and the impact on vehicle speed. While all vehicles are affected by reduced traction on steep inclines, heavy goods vehicles experience the most significant speed reduction due to their weight and limited power reserves. To ensure smooth traffic flow and prevent excessive strain on vehicles, it is generally recommended to keep road gradients below 7%. Table IV.3 provides the maximum gradient values according to the Algerian B40.

Table IV.3. maximum gradient values according to (B40)

Speed (Km/h)	40	60	80	100	120	140
Max gradient (%)	8	7	6	5	4	4

IV.3.3. Transitions in the longitudinal profile

Changes in gradients represent key points in the longitudinal profile and must be smoothed using circular transitions that ensure both visibility and comfort. These transitions are classified into two types: convex (protruding angle) and concave (recessed angle), as illustrated in Figure IV.9. Convex transitions require careful design to maintain comfort and visibility, with minimum allowable radii determined by factors such as human eye positioning, obstacles, and stopping and visibility distances.

Concave transitions, while not posing significant safety risks, are primarily constrained by dynamic comfort, nighttime visibility, and drainage considerations. If an overpass is present, special attention is needed to ensure adequate clearance. Although daytime visibility at low points is less critical, nighttime visibility is essential to guarantee that vehicle headlights illuminate a sufficiently long section of the road, allowing drivers to detect obstacles in advance. This is achieved by selecting an appropriate radius.

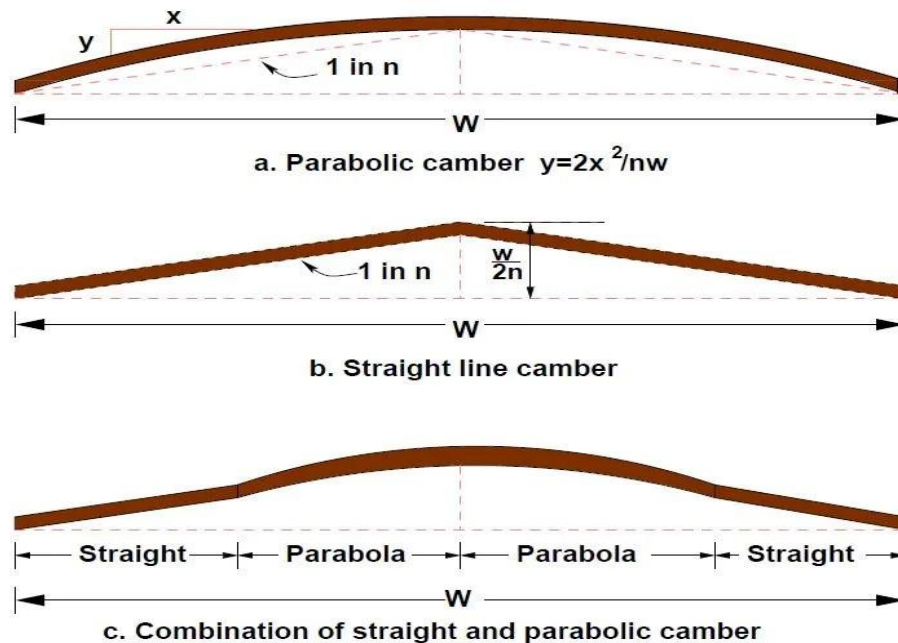

Figure IV.9. Geometric elements of the longitudinal profile. *Source:* Tom V Mathew (2020) <https://civilblog.org/2015/09/08/6-basic-cross-sectional-elements-of-highway-pavement/>

IV.4. Cross-section profile

The cross-section of a roadway is a vertical slice perpendicular to the road's axis, providing a detailed representation of its structural and functional components. This view illustrates all elements that define the road's surface and subsurface layers, ensuring that every design aspect is properly accounted for in construction. Cross-sections are essential in road design as they help engineers visualize the road's width, lane distribution, embankments, slopes, and drainage features. A roadway project consists of multiple cross-sections taken at regular intervals along the alignment, offering a comprehensive view of how the road interacts with the surrounding terrain. These sections are particularly useful in understanding earthwork volumes, ensuring proper load distribution, and optimizing the drainage system to prevent water accumulation and erosion.

To streamline the design process and avoid detailing individual dimensions for each section, a standard cross-section profile is established at the outset. This standardized profile serves as a reference, incorporating all critical geometric and structural details, such as lane widths, shoulders, median strips, embankment slopes, pavement layer thicknesses, and drainage infrastructure. It ensures consistency throughout the project while allowing for necessary adjustments based on local conditions. Additionally, the superstructure layers, including base, sub-base, and asphalt or concrete surfacing, are meticulously defined within the cross-section to guarantee structural integrity and long-term performance.

IV.4.1. Elements of the cross-section profile

Figure IV.10 represents a typical roadway cross-section, illustrating various key components of road design. Below is a definition of each parameter shown in the figure:

- **Right of way:** The total width of land legally designated for road construction and related infrastructure, including embankments, shoulders, and drainage systems.
- **Limit of roadbed:** The outer boundary of the prepared surface on which the pavement structure is constructed. It includes the entire width of the road formation.
- **Roadway:** The full width of the road used by vehicles, including both the carriageway (traffic lanes) and shoulders.
- **Carriageway:** The portion of the roadway that consists of traffic lanes, used exclusively for vehicular movement.
- **Traffic lane:** The designated path within the carriageway for vehicle movement. Multiple traffic lanes make up the carriageway, which may vary in number depending on road classification.
- **Shoulder:** The portion of the road adjacent to the traffic lane, designed to provide structural support, space for emergency stops, and additional safety. It may also serve pedestrians, cyclists, or parked vehicles.
- **Shoulder break point:** The point at which the slope of the shoulder transitions into the embankment. This break prevents water accumulation and enhances road stability.
- **Embankment:** An elevated structure built to support the roadway when the natural ground level is lower than the designed road level. It consists of compacted fill material to ensure stability.
- **Fill:** A layer of compacted soil or material added to raise the road surface to the required elevation, particularly in embankments.
- **Pavement layers:** The structural layers of the road that distribute traffic loads to the subgrade. These typically include the surface course, base course, and sub-base.
- **Sub-grade (Top of fill material):** The prepared surface of the fill material, which serves as a foundation for the pavement layers. Proper compaction is necessary to ensure strength and durability.
- **Capping layer:** An additional layer placed above the sub-grade in weak soil conditions to improve load-bearing capacity and reduce deformation.
- **Sub-grade (Bottom of excavation):** The lowest level of the excavated soil beneath the pavement layers, which serves as the natural foundation for the road.

illustration of these principles and their application in real-world scenarios is depicted in Figure IV.11.

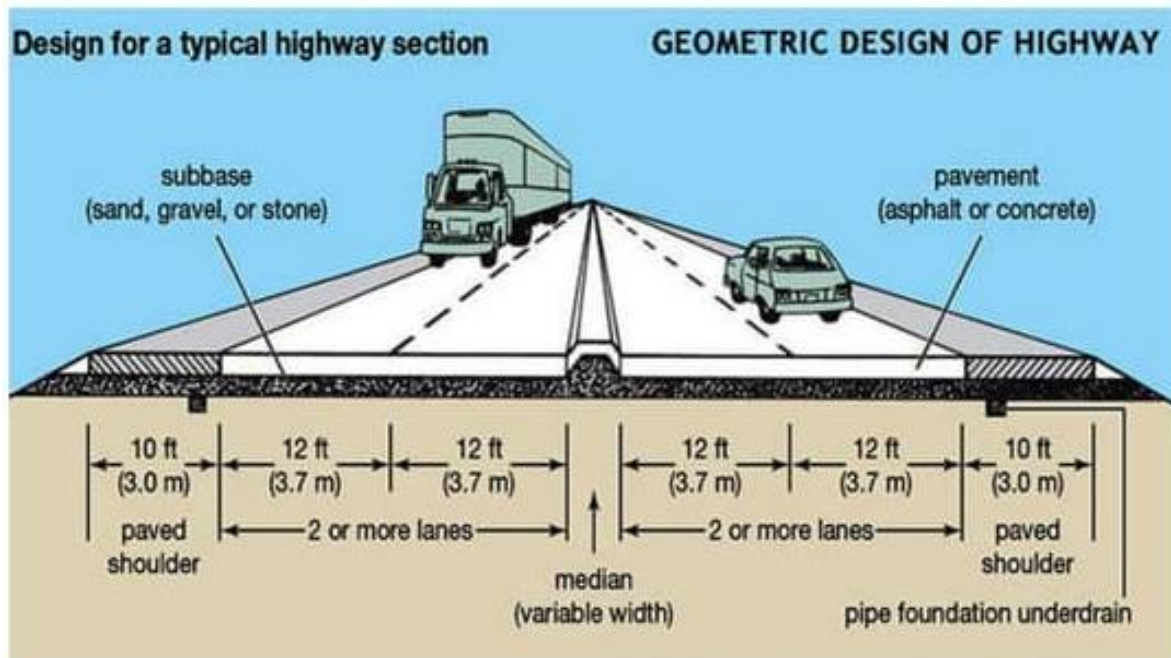

Figure IV.11. Example of Constituent Elements and dimensions of the Cross-Section according to Patrik shinde (2020). Source: <https://fr.slideshare.net/slideshow/geometric-design-of-highway-237575894/237575894>

IV.4.2. Classification of the cross-section profile

Cross-section profiles of roadways can be classified based on various criteria, such as design requirements, function, and the specifics of the road's usage. Below are some common classifications:

- **Standard cross-section**

A standard cross-section is a foundational design used in new road projects or in the modification of existing roads. It includes all the essential construction details and dimensions for the road, applicable in various scenarios (embankments, cuttings). It provides a general template for road design, ensuring consistency and efficiency in construction. Used to determine and calculate excavation volumes and to guide construction practices.

- **Typical cross-section**

A typical cross-section is used at specific intervals, often every 20 meters along the road. It provides a representative example of the road's design and layout. It helps in understanding the road's design at regular intervals and assists in planning and implementing road features and dimensions. Employed for routine checks and adjustments in road construction projects, ensuring that design standards are consistently met.

- **Urban cross-section**

This type of cross-section is designed for roadways within urban areas. It typically includes features like sidewalks, bike lanes, and parking areas. Applied to accommodate the higher density of pedestrian and vehicle traffic in urban settings and to ensure safety and accessibility. Used in city planning and urban road development to address the needs of diverse road users.

- **Rural cross-section**

A rural cross-section is designed for roads in non-urban areas. It often features simpler layouts with fewer design elements, such as minimal or no shoulders. Used to address the lower density of traffic and to accommodate larger vehicle movements, such as agricultural machinery. Applied in the design and construction of roads in rural and agricultural areas.

- **Highway cross-section**

This cross-section is intended for high-speed roads or highways and includes multiple lanes, wide shoulders, and often a central reservation. Applied to ensure safety and efficiency for high-speed vehicular traffic, with adequate space for overtaking and emergency stops. Used in the design of major roads and highways to handle heavy and fast-moving traffic.

- **Low-volume road cross-section**

Designed for roads with low traffic volumes, this cross-section may include narrower lanes and simpler construction features. Applied to provide an economical design solution for roads with limited traffic demands. Used in the construction of local roads or secondary roads with minimal traffic.

- **Drainage cross-section**

This cross-section focuses on the drainage aspects of the roadway, including ditches, culverts, and other water management systems. Applied to effectively manage stormwater and prevent road flooding. Important for maintaining road safety and longevity by addressing water runoff and drainage issues.

- **Geometric cross-section**

This type involves detailed geometric design, including lane widths, shoulder widths, and side slopes. Applied to ensure that the road meets specific geometric standards for safety and operational efficiency. Utilized in detailed design phases to establish precise road dimensions and alignments.

Each type of cross-section profile serves a specific purpose based on the road's function, location, and traffic requirements. Proper classification and design ensure that the road meets safety, functionality, and regulatory standards.

IV.5. Conclusion

The geometric features of traffic lane roads are critical in ensuring safe, efficient, and comfortable travel. Key aspects such as lane width, shoulder design, cross-sectional profiles, and gradient must be meticulously planned to accommodate traffic flow, enhance visibility, and support vehicle maneuverability. Proper design not only optimizes traffic performance but also contributes to overall road safety and user satisfaction. Effective coordination of these geometric elements aligns with regulatory standards and addresses both operational and safety needs, ultimately facilitating a well-functioning transportation network.

Consequently, the last chapter of the present lecture investigates Earthworks in road construction which involve the excavation, movement, and placement of soil and other materials to create a stable and suitable foundation for roads.

Chapter V: Earthworks in Road Construction

V.1. Introduction

Earthworks form the backbone of road construction, providing the foundational structure upon which all subsequent layers of the roadway are built. Road construction earthworks encompass a wide array of activities, including excavation, embankment formation, compaction, and stabilization. These operations involve the manipulation of natural soil and rock materials to create a stable and appropriately shaped platform for the road pavement. Each stage of earthworks demands meticulous planning and execution to address challenges such as soil variability, water drainage, and slope stability.

The chapter begins by exploring the fundamental principles of earthworks, emphasizing the importance of geotechnical investigations and soil classification in determining material suitability and construction methods. It then examines excavation techniques, embankment construction, and the role of compaction in achieving desired soil strength and density.

Additionally, modern advancements in earthwork technologies, such as automated grading systems and soil improvement methods, are discussed to highlight their role in enhancing efficiency and precision. By the end of this chapter, readers will have a comprehensive understanding of the key components of earthworks, their integration into road construction, and the practical measures required to achieve long-lasting and high-quality results. Indeed, this chapter delves into the critical processes, techniques, and considerations involved in earthworks, highlighting their significance in ensuring the durability, safety, and performance of road infrastructure.

V.2. Definition and terminology

In road construction, earthworks encompass a broad range of activities aimed at modifying the natural terrain to meet the geometric and structural requirements of a roadway. This section provides clear definitions and explanations of the key terms and concepts used in earthworks, forming a foundation for understanding the technical processes and methodologies discussed throughout the chapter. Earthworks refer to all activities involving soil movement to modify the natural ground surface, making it suitable for the placement of a predetermined project. This includes:

- Excavating the ground (excavation);
- Transporting the extracted soil (haulage of spoil);

- Depositing or using the soil (embankment, green spaces, etc.).

Earthworks are a delicate phase of a construction project, requiring constant adaptation to soil quality and climatic conditions during execution.

- **Embankment:** This is the process of placing a certain amount of soil to fill a void or to create a mass of soil with a specific geometric shape. The term "embankment" also refers to the soil mass itself. Embankment involves transporting soil from the project site or an external source (borrow pit) that meets the technical specifications.
- **Excavation:** This is the process of digging, including trenches or other excavations. The term "excavation" refers to the soil removed during this process.
 - **Excavated soil:** This soil is used when suitable; however, clayey spoil is not always appropriate for embankments. Excess spoil is deposited, while insufficient soil requires additional excavations from outside the project area, known as borrow pits.
 - **Excavation:** Involves removing and transporting stripped or excavated soil to or from the project site (deposition).
- **Slope of the embankment:** To ensure stable support for embankments or trenches, the slopes of these earthworks must have a proper inclination. This slope can be defined by the tangent or cotangent of the angle between the slope and the horizontal.
- **Platform level (C.P.F):** This is the elevation level assigned to the natural terrain across a defined surface as part of excavation or embankment operations.
- **Deposit:** This is the location where soil from excavation operations is placed.
- **Borrow pit:** This is the location where soil is sourced for embankment construction.
- **Swelling:** This is a property of soils to increase in volume when disturbed, due to partial decompression of soil materials creating voids between particles.
- **Settlement:** Due to atmospheric agents and its own weight, the swelling of an embankment undergoes natural reduction, which may result in significant subsidence requiring reloading, thus leading to a settlement coefficient.
- **Compaction:** Compaction of soil involves reducing its volume through mechanical means (force, vibration, a combination of both, impacts, etc.). This volume reduction occurs only by eliminating the air-filled voids that exist in the soil in its initial state.

Table V.1 provides the swelling and settlement coefficients based on soil types before and after earthworks according to unified soil classification system of the standard practice for classification of soils for engineering purposes ASTM D2487

Table V.1 Swelling and settlement coefficients based on soil types before and after earthworks according to ASTM D2487

Soil type	Condition	Swelling Coefficient	Settlement Coefficient
Clayey Soils	Before Earthworks	30% - 60%	10% - 20%
	After Earthworks	15% - 30%	5% - 15%
Silty Soils	Before Earthworks	20% - 40%	5% - 15%
	After Earthworks	15% - 20%	3% - 10%
Sandy Soils	After Earthworks	10% - 25%	3% - 10%
	Before Earthworks	10% - 20%	2% - 8%
Gravelly Soils	After Earthworks	5% - 10%	1% - 5%
	Before Earthworks	5% - 10%	1% - 5%

V.3. Earthworks objectives

The primary objective of earthworks in road construction is to create a stable and durable foundation that supports the road structure and ensures its long-term functionality under varying traffic and environmental conditions. To achieve this, the earthworks process addresses a range of engineering, environmental, and practical goals.

In road construction, the objectives of earthworks are primarily:

- **Site preparation and soil-terrain modification**

Achieve design elevations: this step aims to alter the natural terrain to reach the elevations and grades specified in the project plans including excavation and embankment. This often involves both cutting (removal of material) and filling (adding material) to establish the desired roadbed profile, as shown in Figures V.1, V.2 and V.3.

Ensure Stability: the preparation of a stable and level surface for the road foundation by removing unsuitable soil and incorporating necessary fill material. This may include compaction and stabilization to prevent future settlement or instability.

- **The creation of a suitable roadbed platform**

To establish a load-bearing foundation, a platform that will support the roadway structure, ensuring it can handle the expected traffic loads and environmental conditions must be built. This involves creating a base that meets both geometric and mechanical quality standards.

To facilitate proper drainage, the design the roadbed is crucial to prevent water accumulation and potential damage to the road structure. This may include grading, drainage ditches, and proper material placement to control water flow.

By focusing on these objectives, earthworks in road construction help ensure a solid foundation for the road, contributing to its longevity and safety.

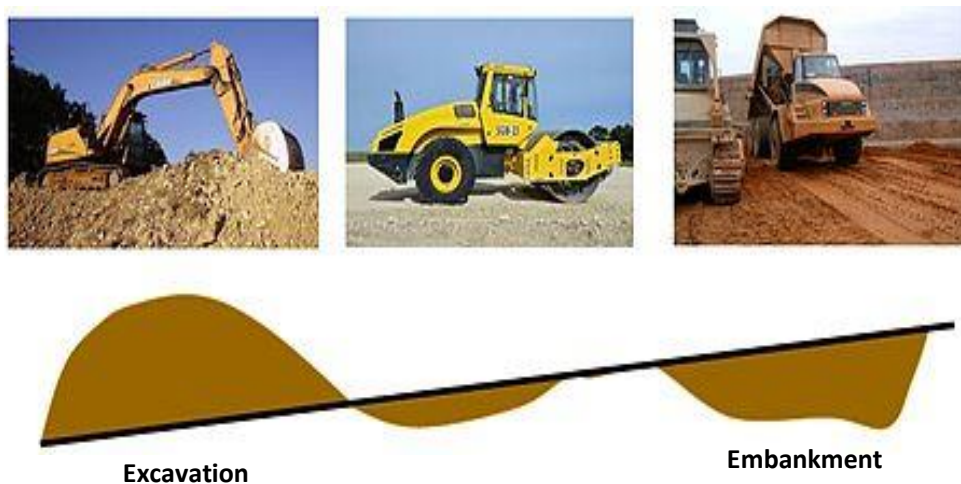

Figure V.1. Examples of site preparation and terrain modification. *Source:* <https://fr.wikipedia.org/wiki/Terrassement>

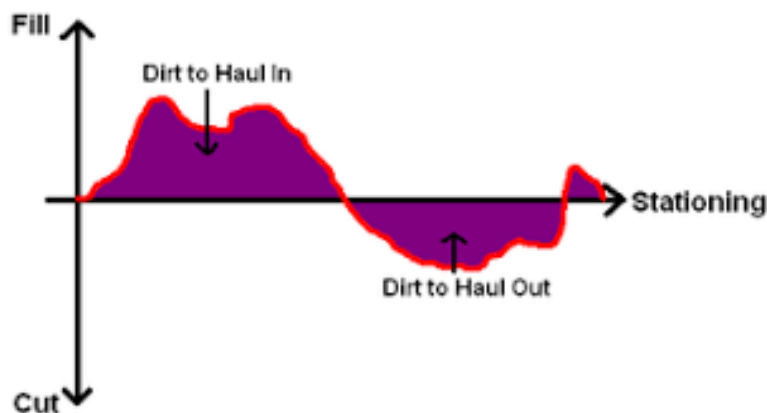

Figure V.2. Embankment and excavation in road construction. *Source:* <https://learncivilengineering.com/wp-content/themes/thesis/images/construction-engineering/Excavation-and-embankment1.pdf>

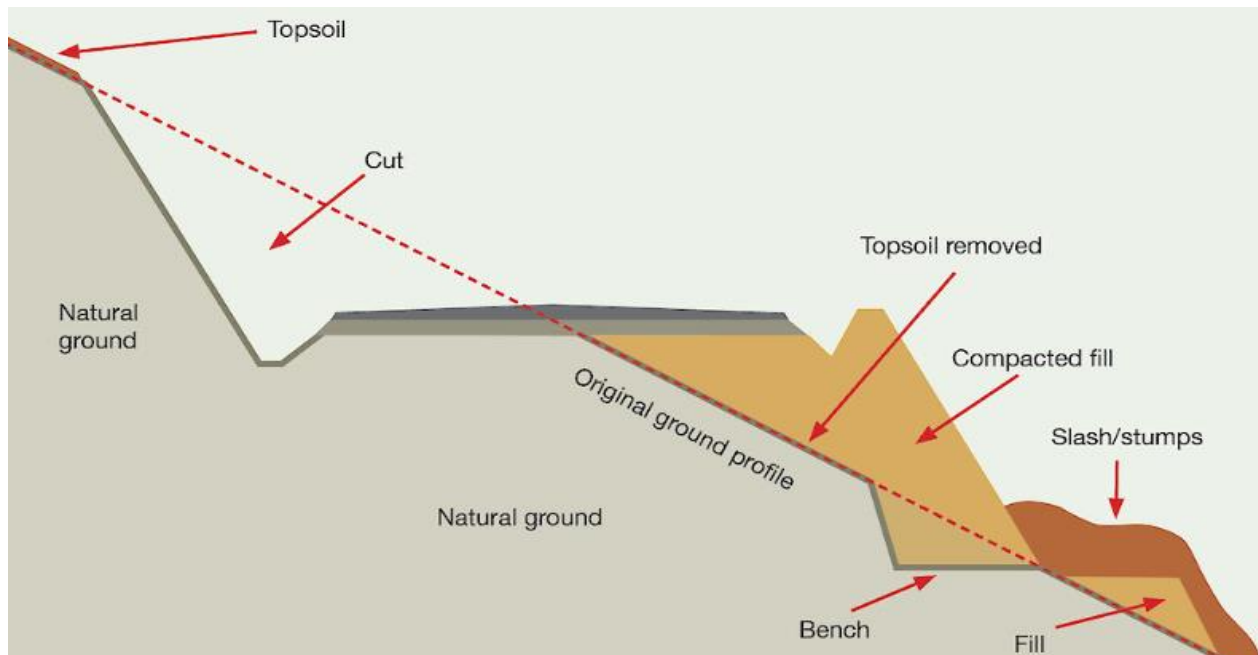

Figure V.3. Terms in earthworks of road construction. *Source: Forest Owners Association* <https://docs.nzfoa.org.nz/lve/nz-forest-road-engineering-manual/5-road-and-landing-construction/5.6-road-formation/>

V.3.1. Execution of embankments

The execution of Embankments refers to the process of constructing raised structures made of soil, rock, or other materials to support infrastructure such as roads, railways, or levees. This process involves several key stages:

- **Site preparation:** Preparing the ground by clearing vegetation, debris, and any unsuitable material, and grading the area to create a stable base.
- **Material selection:** Choosing appropriate fill materials based on factors such as compaction properties, load-bearing capacity, and drainage needs. Common materials include soil, sand, gravel, or crushed stone.
- **Layered construction:** Building the embankment in successive layers or "lifts," with each layer being spread evenly and compacted to achieve the desired density and stability.
- **Compaction:** Using machinery like rollers or compactors to compress each layer of material, reducing voids and increasing the embankment's load-bearing capacity.
- **Drainage and erosion control:** Implementing drainage systems and erosion control measures to manage water flow and protect the embankment from erosion.
- **Quality control:** Conducting inspections and tests to ensure the embankment meets design specifications and quality standards.
- **Final grading and maintenance:** Shaping the embankment to its final profile and performing ongoing maintenance to address any issues that arise over time.

The main objective is to achieve a stable embankment that supports the roadway without any settlement that could compromise its stability. To achieve this objective, the following specific implementation rules and guidelines must be observed:

- Construct the embankment in successive layers using bulldozers
- Compact each layer methodically to achieve the desired density
- Pay particular attention to the upper portion of the embankment, which will support the roadway.

Some real examples of embankment and excavation are illustrated in the below Figures V.4 and V.5



Figure V.4. Examples of embankment and excavation. *Source: Congo soutainement & Habitat Presto* <https://congousoutenement.com/> & <https://www.habitatpresto.com/>



Figure V.5. Execution of embankment. *Source: Indimart & Raubex* <https://www.indiamart.com/> & <https://www.raubex.com/>

V.3.2. Construction of the roadway foundation platform

The construction of the roadway support platform is a critical phase in road construction, forming the foundation upon which the entire pavement structure is built. It ensures the stability, durability, and performance of the roadway by providing a solid base able of withstanding traffic loads and environmental stresses.

The process begins with site preparation, where the area is cleared of vegetation, debris, and unsuitable materials. Topsoil, which contains organic matter and lacks structural integrity, is stripped away to expose more stable soil layers. A geotechnical investigation follows to assess the properties of the underlying soil, including its strength, moisture content, and compressibility. Problematic soils, such as expansive or weak materials, are identified and addressed through replacement or stabilization techniques.

Earthwork operations involve shaping the terrain to match the design profile using cut-and-fill methods. Soil from higher elevations is excavated and transported to fill lower areas, achieving the desired road alignment. Each layer of soil is compacted thoroughly to enhance its density, strength, and load-bearing capacity, reducing the risk of settlement and structural failure. Where necessary, soil stabilization techniques are applied. This may include chemical stabilization using lime or cement to improve soil properties or mechanical stabilization through blending different materials or adding aggregates.

Drainage plays a vital role in maintaining the stability of the support platform. Subsurface drains are installed to prevent water accumulation beneath the roadway, while surface grading ensures proper water runoff, minimizing erosion and waterlogging. The platform is then graded and shaped to meet the specified cross-section and slope requirements, facilitating effective drainage and providing a smooth base for the pavement layers.

Quality control is an integral part of the process. Field tests are conducted to verify that compaction levels meet design standards, and the bearing capacity of the platform is assessed to ensure it can support the anticipated traffic loads. Additionally, protective measures, such as erosion control using silt fences or geotextiles, are implemented during construction to safeguard the platform against environmental factors like rain or wind.

Throughout the construction process, the use of suitable materials, advanced machinery, and adherence to design standards is essential. By carefully executing these steps, the roadway support platform becomes a strong, stable, and durable foundation, ensuring the long-term performance and reliability of the roadway.

To improve and/or protect the existing soil, several solutions are available, including the technique of soil stabilization using hydraulic binders and/or lime, which is a widely used method. Building a roadway support platform is a critical process in road construction that ensures the stability and durability of the roadway structure. Figures V.6-8 provide a comprehensive guide to constructing a roadway support platform.



Figure V.6. Geotextile Installation and platform preparation. *Source: Andrew Lees (2021)* <https://www.tensar.co.uk/resources/articles/what-are-the-different-types-of-road-construction-methods>



Figure V.7. Sub-base layer realization. *Source : Admire Africa* <https://admirafrica.com/>



Figure V.8. Compaction procedure and final platform. *Source :* WikiGeotch & InfoCements <http://wikigeotech.developpement-durable.gouv.fr/> & <https://www.infociments.fr/>

V.4. Treatment of in-Situ soils

The treatment of in-situ soils is a fundamental aspect of road construction, ensuring that the existing ground beneath the roadway meets the required engineering properties to serve as a stable and durable foundation. In-situ soils, which refer to the naturally occurring soil present at the construction site, often exhibit variability in their composition, strength, and behavior. Without proper treatment, these soils may compromise the stability and performance of the road structure.

This section explores the techniques and strategies used to enhance the properties of in-situ soils, addressing challenges such as insufficient strength, high compressibility, poor drainage, or susceptibility to swelling and shrinking. Soil treatment methods aim to improve the load-bearing capacity, reduce settlement risks, and enhance the resistance of the soil to environmental and traffic-induced stresses.

Hydraulic binder treatment of in-situ soils helps avoid the need for external materials on the construction site. Thus, it is both economic and ecological:

- **Enhance soil properties:** Improve the physical and mechanical properties of the soil to meet the structural requirements for roads, parking lots, or industrial platforms.
- **Reduce execution costs:** Minimize the need for importing external materials by treating the existing soil.
- **Environmental benefits:** Utilize local soil and reduce the environmental impact associated with transporting and sourcing materials

The treatment of in-situ soils in road construction is essential to address the natural limitations of the existing ground and ensure the stability, durability, and performance of the roadway. Below are the primary reasons for undertaking soil treatment.

- **Enhancing soil strength and load-bearing capacity:** many natural soils lack the strength required to support the weight of the road structure and traffic loads. treatment methods, such as stabilization with lime or cement, improve the soil's load-bearing capacity, reducing the risk of deformation or failure under applied stresses.
- **Improving soil stability:** some soils, such as clay, are prone to swelling, shrinking, or losing strength when exposed to moisture. treatment stabilizes these soils, making them less susceptible to changes in environmental conditions, which could otherwise compromise the integrity of the road foundation.
- **reducing settlement risks:** compressible soils may lead to uneven settlement over time, causing cracks, rutting, or other structural issues in the roadway. soil treatment minimizes settlement by increasing the density and stiffness of the in-situ material.
- **facilitating proper drainage:** poorly draining soils, such as silts and clays, can retain water, weakening the road foundation and leading to issues like erosion or frost heave. treatment improves the drainage properties of the soil, ensuring the platform remains dry and stable.
- **mitigating the need for excavation and replacement:** without treatment, weak or unsuitable soils may need to be excavated and replaced with imported materials, increasing costs and environmental impact. treating in-situ soils provides a cost-effective and sustainable alternative by improving the properties of the existing ground.
- **adapting to site-specific challenges:** construction sites often feature diverse soil conditions that do not meet design requirements. treatment allows engineers to adapt in-situ soils to varying site conditions, ensuring uniformity and consistency in the road foundation.
- **extending the lifespan of the roadway:** by addressing the deficiencies of natural soils, treatment ensures a more robust and durable foundation, reducing maintenance costs and extending the service life of the roadway.
- **meeting engineering design standards:** road construction projects must comply with strict design criteria for safety and performance. treatment ensures that in-situ soils meet these requirements, providing a reliable base for the overlying pavement layers.

Treatment of in-situ soils in road earthworks involves modifying the properties of existing soil to make it suitable for supporting road construction. This process enhances the soil's bearing capacity, stability, and durability by incorporating additives, typically hydraulic binders, and applying mechanical methods.

V.4.1. Types of soil treatment

Soil treatment in road construction is essential for ensuring that the soil meets the required strength, stability, and durability for supporting road infrastructure. The type of treatment used depends on the soil characteristics, the project's requirements, and the desired outcomes. Here are the main types of soil treatment methods used in road construction:

- **Lime treatment:**

- **Process:** Lime is mixed with the soil to chemically react and improve soil strength and workability.
- **Benefits:** Effective for treating clay soils; improves soil workability and increases strength and durability.
- **Applications:** Used to stabilize wet, clayey soils and enhance soil for road subgrades and embankments.

- **Cement treatment**

- **Process:** Cement is mixed with the soil to enhance its strength and stability through hydration and hardening.
- **Benefits:** Provides significant improvements in load-bearing capacity and durability.
- **Applications:** Suitable for creating stable road bases, subbases, and heavy-load-bearing platforms.

- **Hydraulic binders**

- **Process:** Includes the use of specific binders like Portland cement or other proprietary hydraulic products.
- **Benefits:** Tailored to specific soil types and conditions; offers enhanced mechanical properties and resistance to weathering.
- **Applications:** Used in road construction for both subgrade stabilization and base course improvement.

- **Mixed treatments**

- **Process:** Combines different types of binders, such as lime followed by cement, to leverage the advantages of each.
- **Benefits:** Provides a balanced improvement in soil properties, addressing various soil challenges.
- **Applications:** Effective for soils requiring multiple stabilization approaches for optimal performance.

V.4.2. Works process

The work process involves a sequence of interdependent steps, each designed to address specific characteristics of the soil. It begins with the preparation of the site, which includes clearing, leveling, and assessing soil conditions. This is followed by the application of treatment agents, such as lime, cement, or other stabilizers, depending on the soil type and project specifications. These agents are mixed with the soil using specialized equipment to ensure uniform distribution and effective stabilization. After the preparation of the soil to be treated, the execution process follows these steps:

a) **Binder application** (Figure V.9): To reduce and control the dispersion of the hydraulic binder, it is recommended to use for large-scale projects, a spreader with a weight-based dosage system, controlled by the forward speed.

The consistency of binder application and quantity is checked using the "tarp" method, as shown in Figure V.9.



Figure V.9. Examples of binder application. *Source* : Medium & Structville
<https://structville.com/> and <https://medium.com/>

b) **Mixing** (Figure V.10): To achieve uniform material homogeneity and consistent mixing depth, the use of specialized equipment, such as a horizontal shaft mixer or a compact reconditioning plant, is strongly recommended as shown in Figure V.10. Proper attention is required during the mixing process due to the significant bulking of materials.

Two key considerations include: overlap during treatment when treating in overlapping bands, it is crucial to ensure adequate overlap to maintain uniformity across the treated areas. Secondly, edge mixing with a minimum overlap of 20 cm into the already mixed area is necessary to prevent unmixed material at the edges of the bands.



Figure V.10. Mixing of the soil after the binder application. *Source:* <https://mintekresources.com/soil-stabilization-methods-and-materials/>

c) Compaction (Figure V.11): A critical step in ensuring the strength and stability of the treated soil or material. The specific compaction requirements, including the type of equipment and the number of passes needed, are determined through a compaction test panel. This panel is created on-site to simulate the conditions of the actual construction area and allows for testing different compaction methods and settings.

The test panel helps define the optimal compaction procedure for the specific soil or treated material, ensuring that the required density and load-bearing capacity are achieved. The test panel is typically composed of a small section of the treated material, compacted in stages, to identify the most effective approach for achieving uniform compaction.

One of the most important considerations in compaction is that it must occur immediately after mixing. This is because the material, especially when treated with stabilizers or other additives, is most workable and responsive to compaction while still at its optimal moisture content. Delaying compaction can lead to material setting or drying, reducing its compressibility and the effectiveness of the compaction effort.

Proper compaction is achieved by applying pressure through various means, such as rollers or vibratory compactors, across the entire area as shown in Figure V.11.

Multiple passes are required to ensure that the material reaches the desired density and is evenly compacted. The number of passes will depend on the type of soil, the moisture content, and the compaction equipment used.



Figure V.11. Compaction of the soil platform after mixing. *Source : Terra-Firma*
<https://www.tfsoils.com/>

d) Adjustment (Figure V.12): Final adjustments to the treated surface should be made by planning across the entire width to achieve a uniform and smooth profile, rather than by filling low spots with material removed from high spots, as shown in Figure V.12. This ensures an even distribution of the material and prevents inconsistencies in the surface, which could affect the performance of the road structure.

The adjustment process should immediately follow compaction while the material is still workable, ensuring that the desired road profile is achieved without compromising the integrity of the compacted layer. Typically, a grader is used for this operation, as it allows for precise leveling and smoothing of the surface across the entire width.

Any material that is removed during the planning operation must be properly disposed of, as leaving it on the surface can lead to uneven distribution and possible weak spots. This ensures that the final adjusted surface is clean, consistent, and ready for the next stages of construction.



Figure V.12. Adjustment of the soil platform after compaction. *Source: InfoCements*
<https://www.infociments.fr/>

e) Protective layer with luring product (Figure V.13): The curing product is intended to protect the treated layer from weather, evaporation, and traffic. It should be applied as soon as possible after the adjustment is complete, as shown in Figure V.13. In some cases, where the material to be treated is too dry, it may be necessary to apply water with mixing before spreading the binder to rehydrate the soil. Conversely, if the soil is wet or very wet, mixing without binder can take advantage of favorable atmospheric conditions to promote evaporation.



Figure V.13. Curing products application on the soil platform. *Source: Eco Solution*
<https://www.ecosolutiondistributing.com/coke-processing>

V.5. Road earthworks volume calculation

Road earthworks volume calculation involves determining the amount of earth (soil, rock, or other materials) that needs to be moved to construct or modify a roadway. This process is crucial for planning, budgeting, and executing road construction projects efficiently. Accurate volume calculations help in estimating costs, managing resources, and ensuring the structural integrity and safety of the road.

The choice of method depends on factors like the project's scale, required accuracy, available data, and software tools. For large or complex projects, digital methods offer higher accuracy and efficiency, while traditional methods are still useful for smaller or less detailed projects. Some methods for calculating road earthworks volume are listed below:

V.5.1. Cross-sectional method

This method is commonly used and involves calculating the volume between two or more cross-sections of the road. The assessment is carried out according to the following steps:

- **Examination the soil support:** To begin the process of evaluating the soil support for road construction, it is essential to collect elevation data at regular intervals along the planned road alignment. This data is used to generate cross-sectional profiles of the terrain, which provide a detailed representation of the roadbed's shape at various points along its length. These profiles are crucial for understanding the variability in the terrain and assessing the stability and suitability of the underlying soil for supporting the roadway.
- **Calculating the area of each section:** Once the cross-sectional profiles have been obtained, the next step is to calculate the area of each section. This is typically achieved by applying geometric formulas or utilizing digital tools, such as software designed for civil engineering applications. The area of each section represents the footprint of the soil or material that will support the road structure at that particular point.
- **Computing the volume:** With the area of each section determined, the volume of material required for the roadbed can be computed. This is done by averaging the areas of adjacent sections and multiplying the average area by the distance between them. The result provides the total volume of soil or material that will be involved in the road construction process. This volume calculation using Eq. (V.1) is crucial for planning the amount of material to be excavated or filled, ensuring that the roadbed can be properly constructed to meet design specifications.

$$V = \frac{A_1 + A_2}{2} d \quad (V.1)$$

With (V) is the volume, (A_1 and A_2) are the areas of the cross-sections at the ends, while, (d) is the distance between the cross-sections.

V.5.2. Grid method (or contour method)

This method involves creating a grid over the project area and calculating volumes based on grid points. The assessment is carried out according to the following steps:

- **Grid assessment:** The first step in this process involves laying out a grid over the road area. This grid acts as a framework, with elevation data recorded at each grid point across the site. By systematically surveying these points, we capture the topographic details of the terrain, which will later be used to generate an accurate model of the ground surface. This method ensures that no significant variations in elevation are overlooked, providing a comprehensive view of the landscape.
- **Creating contour lines:** With the elevation data collected from the grid survey, the next step is to draw contour lines. These lines represent locations of equal elevation and help visualize the topographical features of the terrain. Contour lines are essential for understanding the ground's slope and variations, and they form the basis for further calculations in the road construction process.
- **Calculating areas between contours:** Once the contour lines are established, the next step is to calculate the areas between them. This involves determining the space enclosed between successive contours. By calculating these areas, engineers can assess the extent of earthwork required, including the amount of soil to be moved for the road construction.
- **Determining the Volume between contours:** To determine the volume of material that needs to be excavated or filled, integration techniques are applied to the areas between contours using Eq. (V.2). These techniques allow for a precise calculation of the volume of earthwork required, accounting for the gradual changes in elevation across the road alignment. The integration of areas between contours provides a detailed volume estimate, which is crucial for planning material requirements and optimizing construction operations.

$$V = \sum(A_i \times h_i) \quad (V.2)$$

Where (A_i) is the area of each grid cell, and (h_i) the average depth of cut or fill for that cell.

V.5.3. Trapezoidal method

This method approximates the volume between two cross-sections using the shape of a trapezoid. The assessment is carried out according to the following steps:

- **Measuring the areas:** The first step in calculating the volume of material for road construction involves measuring the areas of the cross-sections. These cross-sections, which represent slices of the terrain at various intervals along the road alignment, are essential for understanding the distribution of material.

- **Applying the trapezoidal formula:** Once the areas of the cross-sections are determined, the next step is to apply the trapezoidal formula. This formula is used to calculate the volume of material between two cross-sections by considering the areas of the sections and the distance between them. The trapezoidal formula provides an effective method for estimating the volume, as it approximates the shape of the terrain between two cross-sections as a trapezoid. By multiplying the average of the areas of two adjacent cross-sections by the distance between them, the total volume of material required is calculated. This method ensures an accurate and efficient estimation of the earthwork needed for road construction.

$$V = \frac{b_1 + b_2}{2} h \quad (\text{V.3})$$

With: (V) is the Volume, b_1 and b_2 are the areas of the cross-sections at the ends, while, (h) is the distance between the cross-sections.

V.5.4. Volume of prisms method

The prism method for calculating road earthworks volumes is a technique where the earthwork area is divided into a series of prisms. This method is useful for handling complex terrains and provides a systematic way to estimate the volume of material required for road construction. The assessment is carried out according to the following steps:

- **Determining dimensions:** The first step in calculating the volume of earthwork is to measure the key dimensions of each prism, including the length, width, and height. Each prism represents a segment of the area, defined by the grid cells laid out across the construction site. These dimensions are essential for calculating the volume of material required to achieve the desired road profile.
- **Base area calculation:** Each grid cell forms the base of a prism, and the area of the base must be calculated to determine the overall volume. If the grid cells are rectangular or square, the base area (B) of each prism can be computed using the Eq. (V.4). This base area represents the footprint of the prism at ground level, which is key for calculating how much material is involved in the earthwork process.

$$B = length \times width \quad (\text{V.4})$$

- **Determining the prims height:** The height (H) of each prism is the vertical distance between the existing ground level and the proposed road level at the center of the grid cell. If (E_i) is the elevation of the existing ground and (R_i) is the elevation of the proposed road surface at the same point, then the height of the prism (H_i) is assessed by Eq. (V.5).

$$H_i = E_i - R_i \quad (\text{V.5})$$

- **Volume calculation:** For each prism, the volume (V_i) is given by Eq. (V.6) in which (B_i) is the base area of the prism and (H_i) is the height of the prism.

$$V_i = B_i \cdot H_i \quad (\text{V.6})$$

- **Total volume assessment:** The total volume is given according to number of prisms n as follows:

$$V_{total} = \sum_{i=1}^n V_i \quad (\text{V.7})$$

V.6. Numerical tools in road earthwork volume calculation

Digital terrain models (DTMs) and digital elevation models (DEMs) are 3D representations of the terrain that provide detailed information about the ground surface. They are used to calculate earthworks volumes by comparing existing ground conditions with proposed design surfaces. DEMs are similar to DTMs but may not always include the detailed data required for precise engineering calculations. They offer a grid-based representation of terrain elevation. These models and tools are used in software applications to calculate volumes by comparing the existing terrain to the proposed design. They help in visualizing the terrain and planning earthworks efficiently. The most used software are : AutoCAD Civil 3D, Bentley OpenRoads, and ESRI ArcGIS (Giani et al, 2015).

V.6.1. Geographic Information Systems (GIS)

GIS software allows for the analysis and visualization of spatial data. In road construction, GIS helps in managing terrain data, creating contours, and performing volume calculations. GIS tools can integrate various data layers (e.g., topographic maps, soil types) and perform complex spatial analyses to estimate earthworks volumes, as shown in Figure V.14.

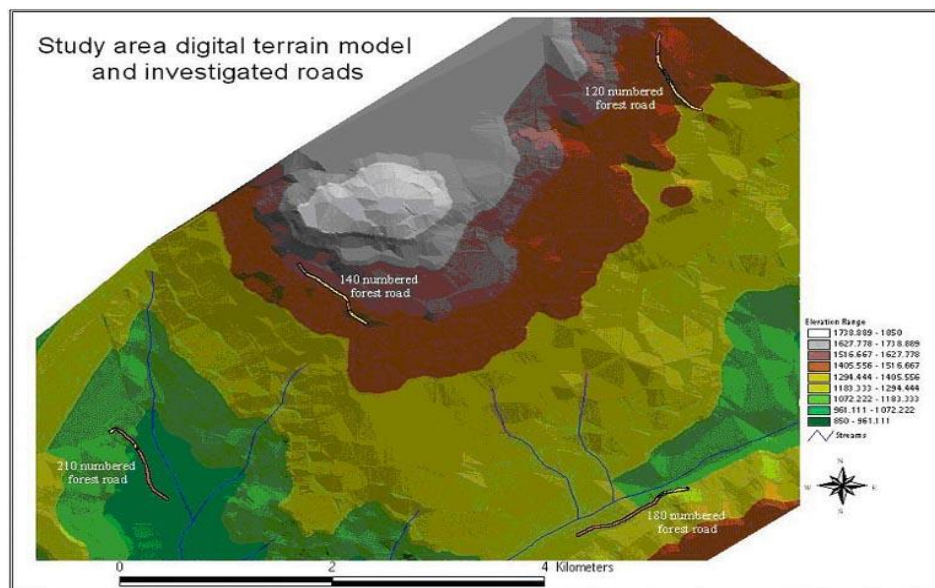

Figure V.14. Example of DTM of the study area and segments of road using GIS. Source: Selcuk Gumus et al : <https://www.fao.org/4/XII/0061-B1.htm>

V.6.2. 3D Modeling and CAD Software

The integration of 3D modeling and Computer-Aided Design (CAD) software has revolutionized the calculation of earthwork volumes in construction projects. These advanced tools provide precise, efficient, and dynamic methods for analyzing terrain and designing road alignments. By creating detailed representations of the existing ground surface and overlaying proposed designs, engineers can accurately determine cut-and-fill requirements, optimize material movement, and streamline project planning.

CAD (Computer-Aided Design) and BIM (Building Information Modeling) software allow for the creation of detailed 3D models of the proposed road and surrounding terrain. These models are used to perform accurate volume calculations.

The software can compute cut and fill volumes, generate cross-sections, and visualize the impact of the earthworks on the overall project, as shown in Figure V.15.

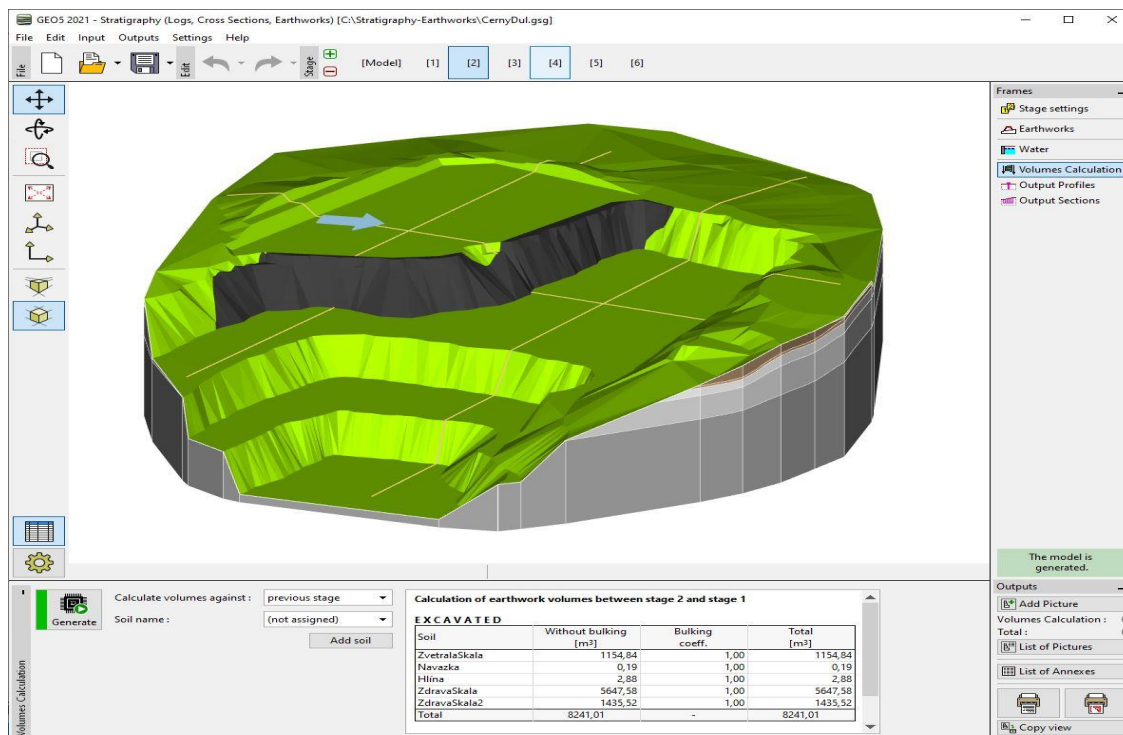

Figure V.15. Example of 3D modeling to assess earthwork volume using GEOS, 2021.
Source: FineSoftware : <https://www.finesoftware.eu/geotechnical-software/stratigraphy-earthworks/>

V.7. Conclusion

Earthworks are a fundamental aspect of road construction, forming the foundation upon which the entire roadway is built. This chapter has provided a comprehensive overview of the principles, methods, and technologies involved in earthworks, highlighting their critical role in ensuring the stability, durability, and functionality of roadways.

As road construction continues to evolve, the integration of traditional practices with modern technologies will be pivotal in addressing future challenges. By leveraging advanced tools and methods, engineers and construction professionals can enhance the accuracy, efficiency, and sustainability of earthworks. This ensures that road projects are completed on time, within budget, and to the highest standards of quality and safety.

Understanding and effectively managing earthworks is essential for the successful completion of road construction projects. The ongoing development of technologies and methodologies will continue to shape the future of road construction, driving innovations that improve performance and meet the demands of increasingly complex infrastructure projects.

References

A. Heriawan. 2020. Upcycling Plastic Waste for Rural Road Construction in India. ADB South Asia Working Paper Series 69. Manila: Asian Development Bank. <https://www.adb.org/publications/upcycling-plastic-waste-rural-road-india>

AASHTO. (1993). AASHTO Guide for Design of Pavement Structures. Washington, DC: American Association of State Highway and Transportation Officials. <https://transportation.org/>

AASHTO. (2009). Transportation and Sustainability Best Practices Background. Sustainability Peer Exchange. Washington, DC: Center for Environmental Excellence, American Association of State Highway and Transportation Officials. <https://transportation.org/>

AASHTO. (2012). Pavement Management Guide, 2nd ed. Washington, DC: American Association of State highway and Transportation Officials. <https://transportation.org/>

ACI. (1956). Structural design considerations for pavement joints. Report of the American Concrete Institute (ACI) Committee 325, ACI Journal, July, p28. <https://www.concrete.org/publications/internationalconcreteabstractsportal.aspx?m=details&i=11500>

Al Kheder, S. Environment-friendly recycled asphalt pavement design for road maintenance applications. Environ Dev Sustain 24, 14210–14234 (2022). <https://doi.org/10.1007/s10668-021-02027-2>

Al Shehhi, A.H.O., Jokhio, G.A., Abu-Tair, A. (2023). Preventive Maintenance Using Recycled Asphalt: Review. In: Al Marri, K., Mir, F., David, S., Aljuboori, A. (eds) BUiD Doctoral Research Conference 2022. Lecture Notes in Civil Engineering, vol 320. Springer, Cham. https://doi.org/10.1007/978-3-031-27462-6_18

Alexander Krylatov , Victor Zakharov , Tero Tuovinen (2020) Optimization Models and Methods for Equilibrium Traffic Assignment, In Springer Tracts on Transportation and Traffic (STTT, volume 15), ISBN: 978-3-030-34102-2, p228 <https://link.springer.com/book/10.1007/978-3-030-34102-2>

- B40.** Normes techniques d'aménagement des routes 1977, Algérie. <https://fr.slideshare.net/slideshow/b40-manuel-de-projeteurs/63864131>
- Bedard, P.** (2010). Car and Driver: How to Drive. Car and Driver. <https://www.caranddriver.com/features/a18199713/patrick-bedard-sometimes-a-car-is-just-a-car-column/>
- Charles Rickard.** (1985). Les autoroutes françaises. Maison d'édition : FeniXX réédition numérique Lavoisier ; EAN13 eBook [PDF] : 9782307548782 Paris, France, p36 <https://e.lavoisier.fr/produit/265463/9782307548782/les-autoroutes-francaises>
- Coquand R.** (1956), Cours de Routes. Tomes 1 et 2. Les éditions Eyrolles, Paris, France, p258 <https://www.eyrolles.com/BTP/Livre/cours-de-routes-tome-1-9782908016895/>
- CTTP.** Catalogue de dimensionnement des chaussées neuves : Fascicule1, 2 & 3, 2001, Algérie. <https://www.gcalgerie.com/catalogue-de-dimensionnement-des-chaussees-neuves/>
- Feng Li, Jinyan Feng, Youxin Li, Siqi Zhou.** (2021). Preventive Maintenance Technology for Asphalt Pavement, In Springer Tracts on Transportation and Traffic (STTT, volume 16), ISBN: 978-981-15-6206-8; p143 <https://link.springer.com/book/10.1007/978-981-15-6206-8>
- French Ministry of Ecological Transition.** (2018). Référentiel de conception des routes - Partie B – Géométrie. NOR : TRAT1815980N developpement-durable.gouv.fr
- G. Doré, H. Zubeck.** (2008). Cold Regions Pavement Engineering. Engineering, Environmental Science. 106472331 ASCE. [https://doi.org/10.1061/41072\(359\)33](https://doi.org/10.1061/41072(359)33)
- Gallivan, F., Ang-Olson, J., and Papson, A.** (2010). Greenhouse Gas Mitigation Measures for Transportation Construction, Maintenance, and Operations Activities. Final Report. NCHRP Project 25-25(58). Washington, DC: Transportation Research Board. [https://onlinepubs.trb.org/onlinepubs/nchrp/docs/NCHRP25-25\(58\)_FR.pdf](https://onlinepubs.trb.org/onlinepubs/nchrp/docs/NCHRP25-25(58)_FR.pdf)
- Garber, N. J., and Hoel, L. A.** (2015). Traffic and Highway Engineering, 5th ed. Stamford, CT: Cengage Learning, p1232. https://archive.org/details/traffichighwayen0000garb_4thedi/page/1232/mode/2up
- Ghilani, C. D., and Wolf, P. R.** (2014). Elementary Surveying: An Introduction to Geomatics, 14th ed. Upper Saddle River, NJ: Pearson. <https://my.civil.utah.edu/~bartlett/CVEEN%202410/texts/Elementary%20Surveying%20-%20Introduction%20to%20Geomatics%20-%2013th%20Edition.pdf>
- Giani, M., Dotelli, G., Brandini, N., and Zampori, L.** (2015). Comparative life cycle assessment of asphalt pavements using reclaimed asphalt, warm mix technology and cold in-place recycling, Resources, Conservation and Recycling, 104, pp. 224–238. <https://www.sciencedirect.com/science/article/abs/pii/S0921344915300665>

Gillespie, T. D. (1992). Fundamentals of Vehicle Dynamics. SAE International. <https://www.sae.org/publications/books/content/r-114/>

Grass, P. T. (2012). Asphalt consumption trends. Technical Presentation, South East Asphalt User/Producer Group Annual Meeting. South East Asphalt User/Producer Group, Ridgeland, MS. <http://seaupg.org/>

Gong, Z., Zhang, L., Wu, J. et al. Review of regulation techniques of asphalt pavement high temperature for climate change adaptation. J Infrastruct Preserv Resil 3, 9 (2022). <https://doi.org/10.1186/s43065-022-00054-5>

HADIDANE Hocine (2018). Contribution à l'amélioration du comportement des corps de chaussées avec l'utilisation des matériaux recyclés. Thèse de doctorat de l'université BADJI-MOKHTAR-ANNABA, Algérie ; p110. <https://biblio.univ-annaba.dz/wp-content/uploads/2019/02/These-Hadidane-Hocine.pdf>

Jeuffroy G. (1967), Conception et construction des chaussées. Tomes 1et 2. Les éditions Eyrolles, Paris, France, p450 https://books.google.dz/books/about/Conception_et_construction_des_chauss%C3%A9es.html?id=A6_VAAAAMAAJ&redir_esc=y

Kalli F.-Z. Cours de routes-conception des tracés routiers et normes. OPU, 2012 ; ISBN : 978.9961.0.1660.2 ; Numéro d'édition : 5413 ; Alger, Algérie ; p146 <https://opu.dz/fr/livre/g%C3%A9nie-civil/cours-de-routes-exrcices-corriges>

Kornilova, A., Pavlova, L., Pavlov, A., Pavlova, L. (2024). Use of Geosynthetic Materials in Road Construction. In: Mantulenko, V. (eds) Proceedings of the 3rd International Conference Engineering Innovations and Sustainable Development. CEISD 2024. Lecture Notes in Civil Engineering, vol 540. Springer, https://doi.org/10.1007/978-3-031-67372-6_26

LCPC (2020). Mesure de l'uni longitudinal des chaussées routières et aéronautiques : Méthode d'essai N°46. Laboratoire central des ponts et chaussées, 58 Boulevard Lefebvre-75732 Paris Cedex 15, France, p 80. www.lcpc.fr & https://www.ifsttar.fr/fileadmin/user_upload/editions/lcpc/MethodeDEssai/MethodeDEssai-LCPC-ME46_4.pdf

M. Rashad Islam, Rafiqul A. Tarefder, (2020). Pavement Design: Materials, Analysis, and Highways, 1st Edition. McGraw Hill Access engineering, ISBN: 9781260458916, New York, USA, p420. <https://www.accessengineeringlibrary.com/content/book/9781260458916>

Malekzadeh, R. (2015). Vehicle Dynamics: Theory and Application. CRC Press. <http://tp.idu.ac.id/>

Margarita Martínez-Díaz (2022). The Evolution of Travel Time Information Systems. In Springer Tracts on Transportation and Traffic (STTT, volume 19), ISBN 978-3-030-89674-4, p289 <https://doi.org/10.1007/978-3-030-89672-0>

Meziani F (2023). Aménagement des voies de communications. Cours de l'université Mouloud Mammeri de Tizi Ouzou, Algérie, p128.

Ministère des Travaux Publics (1977), Normes techniques d'aménagement des routes B40. Alger, Algérie, p86. <https://fr.slideshare.net/slideshow/b40-manuel-de-projeteurs/63864131>

Ministère des travaux publics (2018). Le nouveau code de la route, Texte officiel des lois et décrets entièrement mis à jour. Édition 1929. Code de la route Partie législative Livre 1er : Dispositions générales EAN139782329086224, P40 <https://codes.droit.org/PDF/Code%20de%20la%20route.pdf>

Ministère des Travaux Publics MTP (2001), Catalogue de dimensionnement de chaussées neuves. Alger, Algérie, p129. <https://fr.slideshare.net/slideshow/gcalgeriecom241pdf/251808268>

Nissoux (1989). Chaussées en béton de ciment. Presses de l'école nationale des Ponts et Chaussées ; ISBN 978-2-85978-116-3, Paris, France ; p271 <https://www.eyrolles.com/BTP/Livre/chaussees-en-beton-de-ciment-9782859781163/>

OCDE - Organisation de coopération et de développement économiques (2021). Archive. Paris, rue André-Pascal, 75016, Île-de-France, France <https://www.oecd.org>

P. Kotek, M. Kováč (2015). Comparison of Valuation of Skid Resistance of Pavements by two Device with Standard Methods. Procedia Engineering. 111, 436-443. <https://www.sciencedirect.com/science/article/pii/S1877705815013624?via%3Dihub>

Paul Teodor MARC (2011). Conception et Réalisation de Structures Routières à Hautes Performances. Thèse de doctorat de l'Université POLITEHNICA de Timișoara, Roumanie, p69 <https://theses.fr/2011ART00214.pdf>

Peng Guo, Jiewei Lin, Zefeng Lin, Jinlu Li, Chi Liu, (2021). Analysis and Optimisation of Ride Vibration of a Heavy-Duty Truck Based on a Vertical-Pitch-Roll Driver-Vehicle Coupled Dynamic Model. Academic Editor: Manuel Aenlle Lopez. <https://doi.org/10.1155/2021/6695639>

Petros Ioannou, Andreas A. Malikopoulos (2024). Transportation Mobility in Smart Cities. In Springer Tracts on Transportation and Traffic (STTT, volume 21), ISBN 978-3-031-64768-0, p528. <https://link.springer.com/book/9783031647680>

Russo, N., Filippi, A., Carsana, M. et al. Recycling of RAP (Reclaimed Asphalt Pavement) as aggregate for structural concrete: experimental study on physical and mechanical properties. Discov Civ Eng 1, 99 (2024). <https://doi.org/10.1007/s44290-024-00101-y>

Selcuk Gumus, H. Hulusi Acar, Metin Tunay and Ayhan Atesoğlu. (2011). Calculation of cut and fill volumes by GIS in forest road projecting. Turkey documents ITA 235844.

SETRA Service d'Etudes Techniques des Routes et Autoroute (1994), S Aménagement des routes principales (guide technique), Paris, France, p109 <https://side.developpement-durable.gouv.fr>

Techniques de l'ingénieur. (2011). <https://www.techniques-ingenieur.fr/>

Whiting, E. R. (2011). Driving Safety: Principles and Practices. International Association for the Advancement of Automotive Medicine. <https://www.aaam.org/>

World Health Organization. (2013). Road Safety Manual. World Health Organization. <https://www.who.int/publications/i/item/9789240072497>

Younos, M.A., Abd El-Hakim, R.T., El-Badawy, S.M. et al. Multi-input performance prediction models for flexible pavements using LTPP database. Innov. Infrastruct. Solut. 5, 27 (2020). <https://doi.org/10.1007/s41062-020-0275-3>

Zornberg, J.G., and Gupta, R. (2010). "Geosynthetics in Pavements: North American Contributions. Theme Speaker Lecture, Proceedings of the 9th International Conference on Geosynthetics, Guarujá, Brazil, May, Vol. 1, pp. 379-400